

# Slocum G3 Glider Maintenance Manual

P/N 0000, Rev. 1  
November 2017

(Not for dissemination or reproduction)



Teledyne Webb Research,  
a Business Unit of Teledyne Instruments, Inc.  
49 Edgerton Drive  
North Falmouth, MA 02556  
U.S.A.  
Tel: (508) 563-1000

<http://www.teledynemarine.com/webb-research/>

© Copyright 2017  
Teledyne Webb Research

The material in this document is for information purposes only and is subject to change without notice. Teledyne Webb Research assumes no responsibility for any errors or for consequential damages that may result from the use or misrepresentation of any of the material in this publication.

AquaShield is a trademark of AquaShield, Inc. Drakeol is a registered trademark of Calumet Specialty Products Partners, L.P. Loctite is a registered trademark of Henkel Corp., USA. NatraSorb is a registered trademark of Multisorb Technologies. Royal Purple is a registered trademark of Royal Purple, Inc.

# Contents

- 1 Warnings and Precautions . . . . . 1-1**
  - Electrical Shock . . . . . 1-1
  - Heavy Objects . . . . . 1-1
  - Heavy Parts . . . . . 1-1
  - Pinch Points . . . . . 1-2
  - Hazardous Material Warnings and Safety Precautions . . . . . 1-2
  - General Safety and Handling Precautions . . . . . 1-7
  - Storage Conditions . . . . . 1-8
  - Lifting the Glider . . . . . 1-8
  - Science Sensor Handling . . . . . 1-9
  - O-ring Maintenance . . . . . 1-9
    - Cleanliness . . . . . 1-9
    - Assembly . . . . . 1-9
    - Surface Finishes . . . . . 1-10
  - External Ballast Adjustment . . . . . 1-10
  - Main Hull Double O-ring Seals . . . . . 1-11
  - Comms Port . . . . . 1-12
  - Power Port . . . . . 1-12
- 2 Field Level Maintenance . . . . . 2-1**
  - Glider . . . . . 2-1
    - Disassembling the Glider . . . . . 2-1
    - Assembling the Glider . . . . . 2-5
  - Checking and Setting the Vacuum on the Glider . . . . . 2-9
  - Forward Assembly . . . . . 2-11
    - Removing the Forward Assembly . . . . . 2-11
    - Installing the Forward Assembly . . . . . 2-12
  - Tie Rod Assembly . . . . . 2-13
    - Removing the Tie Rod Assembly . . . . . 2-14
    - Installing the Tie Rod Assembly . . . . . 2-14
  - Tie Rod Plate . . . . . 2-15
    - Removing the Tie Rod Plate . . . . . 2-16
    - Installing the Tie Rod Plate . . . . . 2-16
  - Ballast Bottles . . . . . 2-17
    - Removing the Ballast Bottles . . . . . 2-18
    - Installing the Ballast Bottles . . . . . 2-18
  - Battery Pack . . . . . 2-19
    - Removing the Glider Battery Pack . . . . . 2-21
    - Installing the Glider Battery Pack . . . . . 2-22
  - Leak Detect Assembly . . . . . 2-23
    - Removing the Leak Detect Assembly . . . . . 2-24
    - Installing the Leak Detect Assembly . . . . . 2-24

Recovery Assembly . . . . .	2-25
Removing the Recovery Assembly . . . . .	2-26
Installing the Recovery Assembly . . . . .	2-27
Anode Assembly . . . . .	2-32
Removing the Aft/Forward Anode Assembly . . . . .	2-33
Installing the Aft Anode Assembly . . . . .	2-33
Installing the Forward Anode Assembly . . . . .	2-34
Installing the Recovery Cartridge Assembly . . . . .	2-35
Recovery Spool Base . . . . .	2-40
Removing the 200-meter Recovery Spool Base . . . . .	2-41
Removing the 1000-meter Recovery Spool Base . . . . .	2-41
Installing the 200-meter Recovery Spool Base . . . . .	2-42
Installing the 1000-meter Recovery Spool Base . . . . .	2-42
Altimeter Transducer Assembly . . . . .	2-43
Removing the Altimeter Transducer Assembly . . . . .	2-44
Installing the Altimeter Transducer Assembly . . . . .	2-44
Payload Bay Assembly . . . . .	2-45
Removing the Payload Bay Guard Plate . . . . .	2-46
Installing the Payload Bay Guard Plate . . . . .	2-46
Wings . . . . .	2-47
Removing the Wings . . . . .	2-48
Installing the Wings . . . . .	2-48
Aft Assembly . . . . .	2-49
Removing the Aft Assembly . . . . .	2-50
Installing the Aft Assembly . . . . .	2-51
Stop Plug (Red) and Go Plug (Green) . . . . .	2-52
Removing the Stop Plug (Red) and Go Plug (Green) . . . . .	2-53
Installing the Stop Plug (Red) and Go Plug (Green) . . . . .	2-53
Aft Cowling . . . . .	2-54
Removing the Aft Cowling . . . . .	2-55
Installing the Aft Cowling . . . . .	2-55
De-PINning an Iridium SIM Card . . . . .	2-56
Setup . . . . .	2-56
SIM Check . . . . .	2-56
PIN Deactivation Procedure . . . . .	2-56
Compact Flash Memory Card . . . . .	2-58
Removing the Compact Flash Memory Card . . . . .	2-59
Payload Bay . . . . .	2-59
Glider Main Board . . . . .	2-59
Installing the Compact Flash Memory Card . . . . .	2-59
Payload Bay . . . . .	2-59
Glider Main Board . . . . .	2-59
MS Plug . . . . .	2-60
Removing the MS Plug . . . . .	2-61
Installing the MS Plug . . . . .	2-61

- Attitude Sensor Wiring . . . . . 2-63
  - Removing the Attitude Sensor Wiring . . . . . 2-64
  - Installing the Attitude Sensor Wiring . . . . . 2-64
- Calibrating the True North Compass . . . . . 2-64
- Weight Release Assembly . . . . . 2-65
  - Removing the Weight Release Assembly . . . . . 2-66
  - Installing the Weight Release Assembly . . . . . 2-66
  - Replacing the Burn Wire Assembly . . . . . 2-67
- Main Hull O-Rings . . . . . 2-68
  - Removing the Main Hull O-Rings . . . . . 2-68
  - Installing the Main Hull O-Rings . . . . . 2-68
- 3 Ballasting . . . . . 3-1**
  - Checking and Setting the Vacuum . . . . . 3-1
  - Turning on the Science Sensors . . . . . 3-2
  - Setting the Glider to ballast Mode . . . . . 3-2
  - Immersing the Glider into the Test Tank . . . . . 3-3
  - Adjusting the Glider’s Weight . . . . . 3-3
  - Calculating the H-Moment . . . . . 3-5
    - Calculating the H-Moment. . . . . 3-5
    - Adjusting the H-Moment . . . . . 3-5
- 4 Parts List and Equipment Returns . . . . . 4-1**
  - Ancillary Glider Equipment . . . . . 4-1
  - Instructions for Returning Equipment for Repair or Refurbishment . . . . . 4-2
    - Typical Crate Dimensions . . . . . 4-2
    - Additional Instructions . . . . . 4-3
      - Floats . . . . . 4-3
      - Glider . . . . . 4-3
- A Abbreviations and Acronyms . . . . . A-1**

# Preface

This manual provides the information required to transport, set up, and maintain the Slocum G3 Glider System. This manual is used in conjunction with the *Slocum G3 Glider Operators Manual*. It is divided into the following sections:

- **Section 1—Warnings and Precautions** covers precautions to be taken while maintaining the G3 system. These include general safety warnings, hazardous material handling, and equipment handling.
- **Section 2—Field Level Maintenance** contains step-by-step procedures to be followed in maintaining the G3 system.
- **Section 3—Ballasting** describes how to adjust the mass of the glider so that the glider is neutrally buoyant and properly trimmed at the surface of the operation site water.
- **Section 4—Parts List and Equipment Returns** contains a comprehensive list of the parts and part numbers for the G3 system, along with instructions on how to return equipment for repairs and refurbishment.
- **Appendix—Abbreviations and Acronyms** provides a list of abbreviations and acronyms related to glider maintenance and operations.

## Notes and Warnings

Where applicable, special notes and warnings are presented as follows:



---

**NOTE** A referral to another part of this manual or to another reference; a recommendation to check that certain criteria are met before proceeding further in a step or sequence; or general information applicable to the setup and operation of the Teledyne Webb Research Slocum G3 Glider.

---



---

**CAUTION** Identifies a potential hazard that could be damaging to equipment or could result in the loss of data.

---



---

**WARNING** Identifies a potential hazard that could cause personal injury or death to yourself or to others.

---

## Format Notes

Glider sensors and commands will be denoted in the Courier font throughout this document, as shown in the example below:

Typing `Report ++ m_roll` will report measured roll (`m_roll`) every four seconds.

When displayed on a PC, some areas will be hyperlinked to information available on the Internet, such as:

<http://www.webbresearch.com>

Protected documents are accessible by user account at the TWR Glider User Forum.

Many of the links and the code mentioned in this manual require access by prior arrangement. Please contact [glidersupport@teledyne.com](mailto:glidersupport@teledyne.com) to inquire about access to these protected documents.

## Manual Revision Notice

This manual could be out of date. Always confirm you are working with the latest revision of the manual. To verify that this manual is the most current, visit the TWR Glider User Forum and download the manual or contact [glidersupport@teledyne.com](mailto:glidersupport@teledyne.com).

## Other Manuals and a the TWR Glider User Forum

The G3 glider is supported my multiple documents and the TWR Glider User Forum. This Maintenance Manual focuses on the hardware and how to assemble and disassemble the vehicle and LRU's. The Operators manual outlines the glider's functionality and piloting. Additionally there is a SFMC Manual to explain the Dockserver interface and piloting tools, and there is a Training guide used as reference during Slocum Glider Training sessions. Before operating a glider, it is recommend that all personnel who come in contact the gliders participate in a TWR hosted Training session, be familiar with the material in all these documents and be a member of the TWR Glider User Forum. This manual and many other operations and support material can be found at the TWR Glider User Forum at <https://datahost.webbresearch.com>.

## Customer Service

We welcome your comments and suggestions for improving our products, documentation, and service of the glider system. Please contact [glidersupport@teledyne.com](mailto:glidersupport@teledyne.com) should you have any comments or suggestions about this manual, the glider system, or if you require service or support.

Please contact us at:

**Site URL:** <http://www.teledynemarine.com/webb-research/support>

**E-mail:** [glidersupport@teledyne.com](mailto:glidersupport@teledyne.com)

**Mail:** 49 Edgerton Drive  
North Falmouth, MA 02556

**Telephone:** (508) 563-1000

# General Safety Symbols

The following safety symbols may appear on the glider:



**Read Operator's Manual.**



**Warning. Can cause injury or death.**



**Electrical Shock Hazard.**



**Potential Fire Hazard.**



**Component Corrosion Hazard.**



**Glider and Cart Tipping Hazard.**



**Battery Hazard.**



**Glider Lifting Precaution.**



**Hazardous Material. Cannot be discarded in trash. Disposal must be within Federal, State and local regulations.**



**Potential Leak Hazard.**



# 1 Warnings and Precautions

## Electrical Shock



---

**WARNING** Always shut off the system power before beginning work on equipment.

---



---

**WARNING** Do not come into contact with electrical connectors. Do not be misled by low voltage. Low potentials can also be dangerous.

---



---

**WARNING** Do not work alone on electrical equipment. Be sure another person is nearby who can give first aid.

---

## Heavy Objects



---

**WARNING** Some objects covered in this manual are heavy and need two people to lift them. Muscle strain can occur while loading or unloading the glider and cart.

---

## Heavy Parts



---

**WARNING** A glider in a crate may pose a crushing hazard.

---

## Pinch Points



---

**WARNING** When gliders are assembled and disassembled, certain parts may cause a pinch hazard. Be aware of moving parts that may cause a pinch hazard while locking or unlocking the glider and cart and while disassembling and assembling the glider.

---

## Hazardous Material Warnings and Safety Precautions

Warnings about using and coming into contact with hazardous materials are included throughout this manual. These warnings are designated as shown in the format below. The types of hazardous material warnings that are included in this manual are described below.



---

**WARNING** Chemical warnings indicate that the material will cause burns or irritation to human skin or tissue. Vapor warnings indicate that vapors from a material can be dangerous to life or health. Fire warnings indicate that a material may ignite and cause burns. Eye protection warnings indicate that a material will injure the eyes. When working with these materials, wear the appropriate personal protective equipment (PPE). For more details, see the specific product(s) you are working with in Table 1-1.

---

Personnel working with the G3 system may come into contact with the following hazardous materials. Safety precautions and warnings for these hazardous materials are described in Table 1-1.

**Table 1-1 Safety Precautions and Warnings for Hazardous Materials**

Product Name	Safety Precautions and Warnings
Alkaline Batteries	<p>If the glider contains alkaline batteries, there is a small but finite possibility that batteries of alkaline cells will release a combustible gas mixture, especially if the batteries are exposed to water or sea water and/or shorted. This gas release generally is not evident when batteries are exposed to the atmosphere, as the gases are dispersed and diluted to a safe level. When the batteries are confined in a sealed instrument, the gases can accumulate and an explosion is possible. Teledyne Webb Research has added a catalyst inside of the glider to recombine hydrogen and oxygen into water, and the glider has been designed to relieve excessive internal pressure buildup by having the hull sections separate under internal pressure.</p> <p>Teledyne Webb Research knows of no way to completely eliminate this hazard. The user is warned, and must accept and deal with this risk in order to use this instrument safely as so provided. Personnel with knowledge and training to deal with this risk should seal or operate the instrument.</p>
AquaShield	<ul style="list-style-type: none"> <li>• Avoid contact with skin, eyes, and clothing. Wear the appropriate PPE—eye protection and chemical resistant gloves—while using this product.</li> <li>• Do not breathe vapors or spray mist. Ensure adequate ventilation.</li> <li>• AquaShield 36 X8 may be harmful if swallowed.</li> <li>• Keep people away from and upwind of the spill and/or leak.</li> <li>• Use personal protective equipment.</li> <li>• Keep away from open flames, hot surfaces, and sources of ignition. Fire extinguishers should be readily available when solvent is used for cleaning.</li> </ul>

**Table 1-1 Safety Precautions and Warnings for Hazardous Materials (Continued)**

Product Name	Safety Precautions and Warnings
CSC Lithium Battery	<ul style="list-style-type: none"> <li>• Remove jewelry before handling lithium batteries.</li> <li>• Avoid contact with skin, eyes, and clothing. Wear the appropriate PPE—eye protection and chemical resistant gloves—while handling lithium batteries.</li> <li>• Do not breathe vapors or spray mist. Ensure adequate ventilation.</li> <li>• Sulfuric acid can form if lithium batteries come in contact with water.</li> <li>• Keep people away from and upwind of the spill and/or leak.</li> <li>• If ingested, drink copious amounts of water (or milk, if available). Do not induce vomiting.</li> <li>• Never give anything by mouth to an unconscious person. Immediately seek medical attention.</li> <li>• Keep away from open flames, hot surfaces, and sources of ignition. Fire extinguishers should be readily available when working with batteries.</li> </ul> <p>For more information about handling and working safely with lithium batteries, see the following documents:</p> <ul style="list-style-type: none"> <li>• Electrochem’s product data sheet for lithium sulfur chloride cell batteries at <a href="http://www.electrochemsolutions.com/pdf/high-rate/csc93/3B0030Datasheet.pdf">http://www.electrochemsolutions.com/pdf/high-rate/csc93/3B0030Datasheet.pdf</a>.</li> <li>• Electrochem’s material safety data sheet (MSDS) for lithium sulfuryl chloride cells and batteries at <a href="http://www.electrochemsolutions.com/pdf/CSC_PMX_MSDS.pdf">http://www.electrochemsolutions.com/pdf/CSC_PMX_MSDS.pdf</a>.</li> <li>• <i>Primary Lithium Battery Safety and Handling Guidelines</i> at <a href="http://www.electrochemsolutions.com/pdf/Safety_and_Handling_Guide.pdf">http://www.electrochemsolutions.com/pdf/Safety_and_Handling_Guide.pdf</a>.</li> </ul>
Dielectric Grease	<ul style="list-style-type: none"> <li>• Avoid contact with skin and eyes. Wear the appropriate PPE—eye protection and chemical resistant gloves—while using this product.</li> <li>• Do not breathe vapors or spray mist. Ingestion may cause slight stomach irritation and discomfort. Ensure adequate ventilation.</li> <li>• Keep away from open flames, hot surfaces, and sources of ignition. Fire extinguishers should be readily available when solvents are used for cleaning.</li> </ul>

**Table 1-1 Safety Precautions and Warnings for Hazardous Materials (Continued)**

Product Name	Safety Precautions and Warnings
Drakeol 9 Light Mineral Oil (LT MIN OIL)	<ul style="list-style-type: none"> <li>• Avoid contact with skin and eyes. Wear the appropriate PPE—eye protection and chemical resistant gloves—while using this product.</li> <li>• Do not breathe vapors or spray mist. Ingestion may cause lung inflammation and damage. Ensure adequate ventilation.</li> <li>• Keep away from open flames, hot surfaces, and sources of ignition. Fire extinguishers should be readily available when solvents are used for cleaning.</li> </ul>
Loctite 2440	<ul style="list-style-type: none"> <li>• Avoid contact with skin and eyes. Wear the appropriate PPE—eye protection and chemical resistant gloves—while using this product.</li> <li>• Do not breathe vapors. Loctite 2440 may cause respiratory tract irritation. Ensure adequate ventilation.</li> <li>• Keep away from open flames, hot surfaces, and sources of ignition. Fire extinguishers should be readily available when solvent is used for cleaning.</li> </ul>
Loctite 262	<ul style="list-style-type: none"> <li>• Avoid contact with skin and eyes. Wear the appropriate PPE—eye protection and chemical resistant gloves—while using this product.</li> <li>• Do not breathe vapors. Loctite 262 may cause respiratory tract irritation. Ensure adequate ventilation.</li> <li>• Keep away from open flames, hot surfaces, and sources of ignition. Fire extinguishers should be readily available when solvent is used for cleaning.</li> </ul>
Loctite 567 Pipe Sealant	<ul style="list-style-type: none"> <li>• Avoid contact with skin and eyes. Wear the appropriate PPE—eye protection and chemical resistant gloves—while using this product.</li> <li>• Do not breathe vapors. Loctite 567 may cause respiratory tract irritation. Ensure adequate ventilation.</li> <li>• Keep away from open flames, hot surfaces, and sources of ignition. Fire extinguishers should be readily available when solvent is used for cleaning.</li> </ul>

**Table 1-1 Safety Precautions and Warnings for Hazardous Materials (Continued)**

Product Name	Safety Precautions and Warnings
NatraSorb S	<ul style="list-style-type: none"> <li>• Avoid contact with skin and eyes. Wear the appropriate PPE—eye protection and chemical resistant gloves—while using this product.</li> <li>• Ingestion is unlikely, but if ingested, blockage may occur. Get medical attention.</li> </ul>
Parker O-Lube	<ul style="list-style-type: none"> <li>• Avoid contact with skin and eyes. Wear the appropriate PPE—eye protection and chemical resistant gloves—while using this product.</li> <li>• If ingested, immediately drink two glasses of water, induce vomiting, and seek medical attention.</li> <li>• Keep away from open flames, hot surfaces, and sources of ignition. Fire extinguishers should be readily available when solvent is used for cleaning.</li> </ul>
Parker Super-O-Lube	<ul style="list-style-type: none"> <li>• Avoid contact with skin and eyes. Wear the appropriate PPE—eye protection and chemical resistant gloves—while using this product.</li> <li>• Keep away from open flames, hot surfaces, and sources of ignition. Fire extinguishers should be readily available when solvent is used for cleaning.</li> </ul>
Royal Purple Hydraulic Oil	<ul style="list-style-type: none"> <li>• Avoid contact with skin and eyes. Wear the appropriate PPE—eye protection and chemical resistant gloves—while using this product.</li> <li>• Do not breathe vapors. Ensure adequate ventilation.</li> <li>• Keep away from open flames, hot surfaces, and sources of ignition. Fire extinguishers should be readily available when solvent is used for cleaning.</li> </ul>
Sea-Bird Anti-Foulant Device (AF24173)	<ul style="list-style-type: none"> <li>• Avoid contact with skin and eyes. Wear the appropriate PPE—eye protection and chemical resistant gloves—while using this product.</li> <li>• Do not breathe vapors. AF24173 may cause respiratory tract irritation. Ensure adequate ventilation.</li> <li>• Keep away from open flames, hot surfaces, and sources of ignition. Fire extinguishers should be readily available when solvent is used for cleaning.</li> </ul>

# General Safety and Handling Precautions

General safety and handling precautions that will help avoid personal injury as well as damage to the glider include the following:

- Only trained and authorized personnel should handle the glider.
- Internal maintenance must be performed only by trained and authorized personnel.
- Only trained and authorized personnel should be permitted to operate/deploy the glider.
- Ensure that the glider is powered down properly before removing the green plug.
- Rinse the glider with fresh water after exposure to salt water.
- Never apply greater than 15 volts with a power supply.
- The internal electronics of the glider is sensitive to electrostatic discharge (ESD). Proper precautions must be used at all times when handling any of the glider's electronic components.
- Never connect or disconnect any electrical connections while the system power is on, as damage to electronics could occur.
- Always refer to this maintenance manual before and during any maintenance operations.
- Always refer to the operator's manual for the glider before and during deployment operations.
- When Teledyne Impulse connections are mated, care to the alignment of pins and proper seating of the connector should be taken.
- Carbon fiber hulls should be handled carefully. The O-ring sealing surfaces should be inspected for scratches and defects that could lead to a leak.
- Minor scratches to paint and anodizing should be touched up with automotive paint or nail polish.
- O-rings should be inspected for cleanliness, nicks, and slices. O-ring surfaces should also be inspected for scratches, dents, and cleanliness. Parker Fibrous O-Lube 884-4 (Petroleum Naphthenic Oil and Barium Soap) is recommended. Wear the appropriate PPE—eye protection and chemical resistant gloves—while using these products.
- Rinse the pressure transducer thoroughly with fresh water after each saltwater deployment.
- The internal electronics of this equipment are sensitive to electrostatic discharge (ESD) and proper precautions must be adhered to when handling any electrical components of the system.
- Never power a shallow glider without a vacuum.
- Never run a simulation on a glider other than `on_bench`.
- Never deploy a glider in simulation.
- Never deploy a glider in `boot pico`.
- Never exit to `pico` during a deployment.
- Never deploy a glider in `lab_mode`.

- Never perform the top of a yo below 30 meters (with 100- or 200-meter pumps).
- Never secure the glider to the glider cart while the cart is not secure or over the railing or in the water.
- Always observe warnings at all times.
- Always secure the glider properly in crate with all the straps for shipping.
- Significant damage to equipment can occur if it is not properly secured. This is true at all times, in the lab, during transportation and while being deployed. The glider cart should be used during maintenance. When parts are removed from the cart, caution must be taken to secure the cylindrical pieces as they can roll off of surfaces.
- Always use fresh desiccants for each deployment.
- Always monitor internal vacuum before launch (less vacuum indicates a leak; positive pressure may indicate dangerous gas accumulation). The vacuum will fluctuate with temperature.
- Always simulate missions before launch.
- Always test Iridium and Argos telemetry before launch.
- To care for dummy and green plugs, use OLube lubrication or silicone spray and keep contact pins clean.
- The ejection weight can come out with moderate force (do not stand behind and activate).

## Storage Conditions

For optimum battery life, the storage temperature range is +10 to +25 degrees C. When activated, the glider should be equilibrated at a temperature between -2 and +54 degrees C.

## Lifting the Glider

Lifting the glider is a two-man operation. When in the laboratory, it is generally easier to lift the glider while it is strapped to the cart. One person should lift the glider at the forward end and another at the aft end. Please note that the glider is heavier at the forward end.

Be sure to follow proper lifting procedures:

- Plan before you lift—You and your lifting partner need to know what you are doing and where you are going to prevent any awkward movements. Also make sure your path is clear.
- Lift the glider close to your body—You have more strength when you lift close to your body than when you lift at arm's reach. Make sure you have a firm grip on the glider, and keep it balanced close to your body.
- Keep your feet shoulder width apart to improve your support and balance. Take short steps while moving the glider.
- Bend with your knees, and keep your back straight.



- Tighten your stomach muscles while you are lifting the glider. Tight abdominal muscles hold your back in a good lifting position and prevent excessive force on the spine.
- Lift the glider with your legs. Your leg muscles are much stronger than your back muscles. Also lower the glider with your legs when you are finished moving it. While you are lifting, keep your eyes focused upward so that your back remains straight.
- Wear a belt or back support to maintain a better lifting posture.

## Science Sensor Handling

Each manufacturer's recommendation for service and care should be followed. Some sensors, especially those protruding, may need special handling during deployment, recovery and shipping to prevent damage. Individual sensors may have special needs. See manufacturer's recommendations.

## O-ring Maintenance

Following is an excerpt from the *Parker O-Ring Handbook*. This handbook is available for download at:

[http://www.parker.com/literature/ORD%205700%20Parker\\_O-Ring\\_Handbook.pdf](http://www.parker.com/literature/ORD%205700%20Parker_O-Ring_Handbook.pdf)

## Cleanliness

Cleanliness is vitally important to ensure proper sealing action and long O-ring life. Every precaution must be taken to ensure that all component parts are clean at time of assembly. Foreign particles—dust, dirt, metal chips, grit, etc.—in the gland may cause leakage and can damage the O-ring, reducing its life.

## Assembly

Assembly must be done with great care so that the O-ring is properly placed in the groove and is not damaged as the gland assembly is closed. Some of the more important design features to ensure this are:

1. The inside diameter stretch, as installed in the groove, should not be more than 5%. Excessive stretch will shorten the life of most O-ring materials.
2. The inside diameter expansion needed to reach the groove during assembly ordinarily does not exceed 25-50% and should not exceed 50% of the ultimate elongation of the chosen compound. However, for small diameter O-rings, it may be necessary to exceed this rule of thumb. If so, sufficient time should be allowed for the O-ring to return to its normal diameter before closing the gland assembly.
3. The O-ring should not be twisted. Twisting during installation will most readily occur with O-rings having a large ratio of inside diameter to cross-section diameter.

## Surface Finishes

All mating surfaces for the O-ring must also be regularly inspected and cared for to maintain the finish and ensure a proper seal.

## External Ballast Adjustment

G3 gliders are equipped with external ballast in four locations: the buoyancy pump, the port and starboard wing rails, and the tail cowling. All of the external ballast weights are of the same form factor and weigh approximately 13 grams in water. The aft weight holder can be populated with up to 9 weights, each wing rail, 10 weights, and the forward section, 16 weights. The default configuration is to half populate each section, maximizing the capability to adjust buoyancy in the field. This leaves some  $\pm 220$  grams of adjustability which equates to  $\pm 3.3\sigma$  density variation in a standard length glider, i.e.,  $\pm 0.194\sigma/\text{weight}$ . Due to their small size, the external ballast weights will have negligible effects on vehicle pitch, roll and H-moment (stability).

External ballast weight pockets should be configured to half populated during ballasting so as to maximize flexibility in the field. Weights may be pressed into desired pockets and removed using a small screw driver, hex key, etc. To gain access to the wing rail weights, remove the 5/32-inch socket head cap screws securing the fore and aft of the wing rails. To gain access to the aft weight holder, deflate the air bladder and remove the tail cowling by loosening and removing the socket head cap screws securing the aft cowling. To access to the buoyancy pump weight pockets, remove the four 7/64-inch socket head cap screws securing the sonar nose dome (or peek nut for recovery strobe dome models).

External ballast weights should be stored dry and rinsed with fresh water after exposure to salt water.

If possible, plan operations for a vehicle maximizing the use of autoballast and external ballast so as to minimize the number of times that you need to open the vehicle to adjust ballast.



**Figure 1-1 External Ballast Weights**

## Main Hull Double O-ring Seals

One of the enhancements with the G3 Glider is that all hull sealing surfaces use two o-rings. By increasing the sealing surface area, G3 gliders have a reduced possibility of a leak occurring on a hull sealing surface. The O-ring part number for a double seal application is 340697. The lubricant used is Parker OLUBE 884-4. The same procedures used for the G2 glider is used for lubrication of the O-rings and hull sealing surfaces (3135-LUBE), available at the TWR Glider Forum or by request from [glidersupport@teledyne.com](mailto:glidersupport@teledyne.com). The O-rings and O-ring surfaces should be inspected, and the O-rings should be replaced, if necessary, before each glider deployment.



*Figure 1-2 Double O-ring Seal*



**NOTE** The additional O-ring resulted in the Carbon fiber hulls needing to increase in length by .5 inches from that of the G2 glider. This change increased the total vehicle displacement for a “standard configuration” G3 to 57.7 liters. The internal tie rod was lengthened and G2 hulls will not fit on G3 gliders.



**CAUTION** Debris and damage to sealing surfaces can result in a leak which can incapacitate or cause the loss of the glider. It is critical that sealing surfaces remain clear of debris and that no sharp edges or tools are used. Damage to the hull sealing surface or the O-ring grooves must be repaired and the glider pressure tested before it is operational ready.

## Comms Port



---

**NOTE** The shell that screws in and holds the comms connector in place must be present and firmly seated before deployment. This shell needs to be removed to remove or install the aft cowling.

---

## Power Port

New with the G3 glider is the power port. This port can be used with a 6-pin green shorting plug (300128 Shorting plug), also new with the G3 glider, to activate the batteries and power the glider for deployment. Like the previous G1 and G2 gliders, this port can also be used for shore power. When using shore power, do not exceed 16 volts.



---

**CAUTION** Operators should be aware of the new BSM board and that the G3 glider must be powered down properly. The BSM board requires that the glider be properly commanded to power off, and the operator must wait for the “safe to remove power” message. Failure to properly shut down will result in the BSM board emitting a tone and ultimately in the emergency circuit becoming active. If powered down incorrectly, the glider should be powered up and then powered down properly.

---



---

**NOTE** The shell that screws in and holds the power connector in place must be present and firmly seated before deployment. This shell needs to be removed to remove or install the aft cowling.

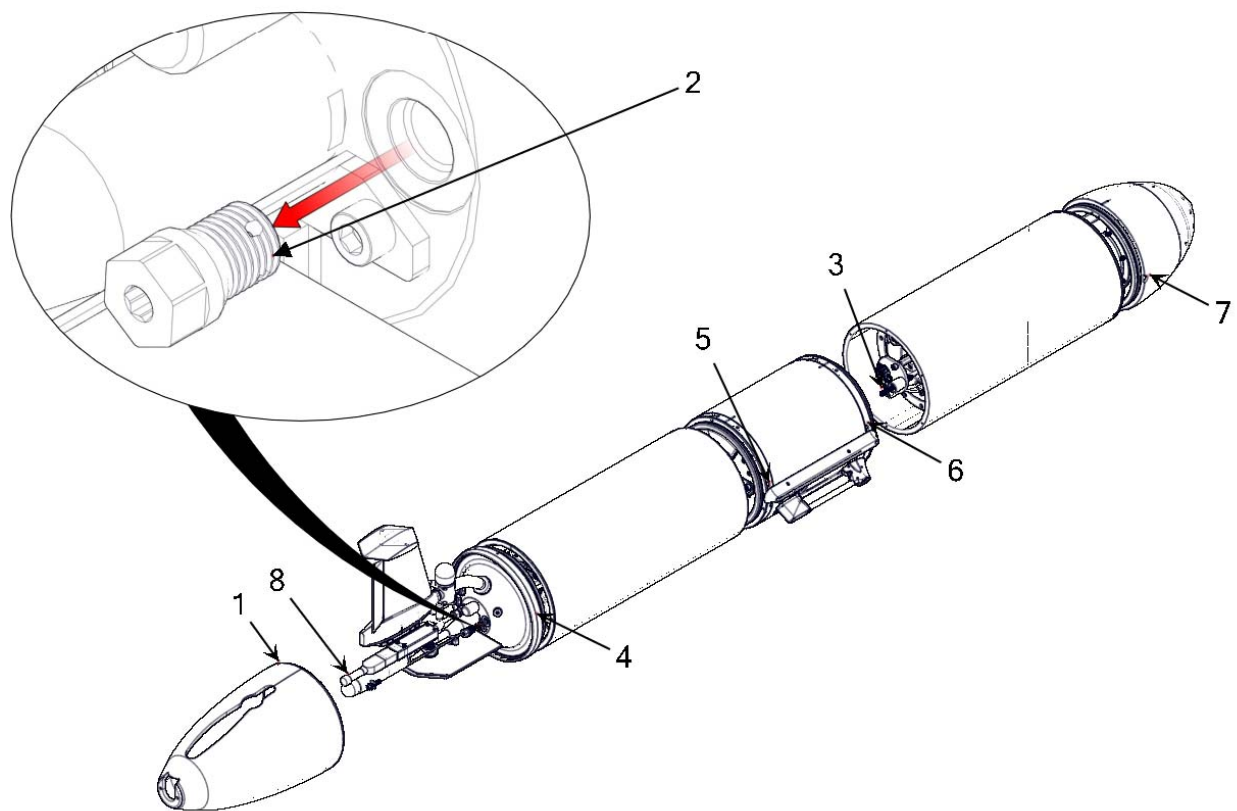
---

# 2 Field Level Maintenance

## Glider

Tools:	Glider Maintenance Accessory Kit
Materials and parts:	Glider (200 or 1000 meters)
Personnel required:	2 electronics technicians

### Disassembling the Glider



**Figure 2-1 G3 Glider (G2 proxy graphic shown for reference).**



---

**CAUTION** The air bladder must be deflated before the glider can be disassembled. From the GliderDOS prompt, type "put c\_air\_pump 0" to deflate the air bladder.

---



---

**CAUTION** The retaining shells, which are new with the G3 glider along with the comms and power port plug on the top end cap, must be removed to remove the tail cone.

---



---

**CAUTION** The user must issue the "exit" command to the glider from a terminal and be instructed by the glider that it is OK to remove power before the Go plug (green) or external power can be removed. Failure to do so may result in corruption of the file system which will render the glider inoperable. Failure to properly shut down will result in the BMS board emitting a tone and ultimately in the emergency circuit becoming active.

---



---

**WARNING** Lifting the glider requires two persons. Failure to comply with this requirement may result in injuries to personnel or damage to equipment.

---

1. When properly shut down, ensure that the power to the glider is off by removing the Go plug (green) and replacing it with the Stop plug (red).
2. Remove the aft cowling (Figure 2-1, Item 1) by removing the two 10-32 socket head cap screws and washers using the 5/32" x 12" red T-handle hex wrench. Remove the two shells from the power and comms connectors at the top of the aft cap. Grasp the cowling and pull aft to separate the cowling from the aft endcap. Gently spread the top of the cowling to allow it to slide off around the fin.
3. Using the 15 inch-pound torque T-handle, 24" extension and 3/16" hex bit, remove the 7/16 x 20 PolyEtherEther-Ketone (PEEK) military standard (MS) vacuum seal plug (Figure 2-1, Item 2).

- Using the same tool assembly, insert the 3/16" hex bit into the vacuum seal port and engage the tie rod end. Unscrew the tie rod until tension is felt, then separate the aft endcap/aft tray assembly (Figure 2-1, Item 3) from the aft hull using the hull separator tool.



---

**CAUTION** Take care not to damage the seal area or the threads with the side of the tool assembly.

---



---

**NOTE** Each hull section can be separated by several inches to access the inside of the vehicle. If greater access is needed, the wiring from and to the payload bay or payload section must be disconnected.

---



---

**NOTE** Some legacy gliders may not have the "half moon" cutouts on the aft endcap. If not present, the aft endcap/aft tray assembly may be separated from the aft hull by grasping the tail fin or tail fin tube and gently moving the aft endcap up and down to separate it from the hull.

---

- Unscrew the tie rod until it disengages from the tie rod receiver in the forward section (or add-on module).
- Using the hull separator tool, separate the aft hull (Figure 2-1, Item 5) from the payload bay aft stiffener ring.
- Slide the aft hull and aft endcap/aft tray assembly aft about three inches.



---

**NOTE** There may be other connectors that are specific to the glider. Disconnect these as appropriate.

---

- Remove the aft endcap and tray assembly and set it aside in a cradle or other secure receiver.
- If lithium batteries are installed, remove the two pins securing the battery to the battery mounting bracket on the aft payload by the guard plate. Carefully remove the aft battery and set it aside in a secure location.

If alkaline batteries are installed, remove the two 1/4-20 socket head cap screws and washers securing the battery to the battery mounting posts on the aft science bay stiffener ring. Carefully remove the aft battery and set it aside in a secure location.

- Remove the aft hull and set it aside. Be careful not to damage the hull.

If there is an energy bay or other add-on module installed, continue with Step 11. If not, go to Step 19.

11. Using the hull separator tool, separate the payload bay from the add-on module.
12. Slide the payload bay back about three inches.
13. Remove the payload bay and set it aside.



---

**NOTE** There may be other connectors that are specific to the glider. Disconnect these as appropriate.

---

14. Using the 15 inch-pound torque T-handle and 5/32" hex bit, insert the bit into the tie rod receiver of the add-on module and unscrew the tie rod extension between the add-on module and the forward section.
15. Using the hull separator tool, separate the add-on module from the forward section.



---

**NOTE** Some gliders may not have the "half moon" cutouts on the add-on module. If not present, the add-on module may be separated from the forward section by grasping the add-on module hull and gently moving the module up and down to separate it from the hull.

---

16. Slide the add-on module back about three inches.
17. If using lithium batteries, disconnect the battery enable connector.



---

**NOTE** There may be other connectors that are specific to the glider. Disconnect these as appropriate.

---

18. Remove the add-on module and set it aside, then proceed to Step 23.
19. Using the hull separator tool, separate the payload bay from the forward hull.
20. Slide the payload bay back about three inches.
21. If using lithium batteries, disconnect the battery enable connector.



---

**NOTE** There may be other connectors that are specific to the glider. Disconnect these as appropriate.

---

22. Remove the payload bay and set it aside.



23. Insert the 5/32" x 12" red T-handle hex wrench into the battery mount shoulder screw and unscrew the pitch battery from the forward section.
24. Carefully slide the pitch battery out of the forward section and set it aside.
25. Using the hull separator tool, separate the forward hull from the forward section. Slide the hull aft and carefully remove it and set it aside.
26. The glider sections can now be re-assembled on the glider cart (without the forward and aft hulls and main batteries) for service.

## Assembling the Glider



---

**WARNING** Lifting the glider requires two persons. Failure to comply with this requirement may result in injuries to personnel or damage to equipment.

---



---

**CAUTION** If assembling the glider for the final time before deployment, a careful visual inspection should be performed on all internal components. Inspection check lists can be provided on request.

---



---

**CAUTION** When the glider is sealed for the final time before a deployment, a full functional test of the glider system should be performed. Contact [glidersupport@teledyne.com](mailto:glidersupport@teledyne.com) for a copy of the test procedure.

---



---

**NOTE** The hull sections must be aligned parallel and at the same height to allow them to fit together. It is recommended that this work be done on the glider cart.

---

1. Ensure that power is not applied to the vehicle and that the Stop plug (red) is installed.
2. Place the glider cart on a flat, level surface and lower or remove the nose ring.
3. Place the forward hull on the cart, making sure the orientation is correct. The SLOCUM G3 labels should be forward on the port and starboard sides.
4. Clean and inspect the double O-ring sealing surfaces of the forward hull, making sure there are no scratches or other damage that could cause the O-ring to fail.

5. Clean and inspect the forward section O-ring and O-ring groove and re-lubricate or replace it as necessary.
6. Carefully insert the forward section into the forward hull, being careful not to scratch or damage the interior of the hull, particularly the area near the ends where the O-rings seat.
7. Align the index marks on the forward hull and forward endcap, and then press the forward section into the hull, making sure the O-rings do not get pinched or damaged.
8. Place a drop of Loctite 243 (blue) on the pitch battery mounting screw.
9. Carefully insert the pitch battery into the open end of the forward hull, making sure the forward cable harness and connectors feed through the center opening of the battery and being careful not to damage the interior of the hull.
10. Secure the pitch battery to the forward section by tightening the pitch battery mounting screw with the 5/32" x 12" red T-handle hex wrench.
11. If using lithium batteries, connect the battery enable connector JH133 from the LI EM BAT connector on the forward harness.




---

**CAUTION** Take care when mating connectors, as the pins are delicate.

---

If there is an energy bay or other add-on module to install, continue with Step 12. If not, go to Step 17.

12. Clean and inspect the add-on module O-rings and O-ring grooves and re-lubricate or replace as necessary.
13. Place the add-on module on the glider cart aft of the assembled forward section.
14. Make the connections from the forward section wiring harness and from the pitch battery to mating connectors on the add-on module forward guard plate. Ensure that the battery cable can move freely, as it must flex as the pitch battery moves.




---

**NOTE** There may be other connectors that are specific to the glider. Connect these as appropriate.

---




---

**NOTE** Always visually confirm that no internal wires or other obstructions will prevent glider sections from being drawn together properly while sealing.

---

15. Align the index marks on the add-on module and the forward hull.
16. Using the 15 inch-pound torque T-handle and 5/32" hex bit, close the two sections. Make sure the O-rings do not get pinched or damaged.
17. Clean and inspect the payload bay forward and aft O-rings and O-ring grooves and re-lubricate or replace them as necessary.
18. Place the payload bay on the glider cart aft of the forward hull and, if present, the add-on module.
19. Make the connections from the forward section wiring harness and from the pitch battery to mating connectors on the payload bay forward guard plate.



---

**NOTE** If an add-on module is installed, the connectors are labeled.

---



---

**NOTE** There may be other connectors that are specific to the glider. Connect these as appropriate.

---

20. Slide the payload bay and the forward hull or add-on module together, keeping the index marks aligned. If no add-on module is present, ensure that the battery cable can move freely, as it must flex as the pitch battery moves.
21. Place the aft hull on the glider cart making sure the orientation is correct. The Teledyne Webb Research label should be aft and on top.
22. Clean and inspect the O-ring sealing surfaces of the aft hull, making sure there are no scratches or other damage that could cause the O-rings to fail.
23. Carefully insert the aft battery into the aft hull, with the mounting bracket towards the payload bay.
24. Slide the aft hull and battery to three inches from the payload bay, and then slide the battery out towards the payload bay. Connect the battery mounting bracket to the payload bay. For lithium batteries, mount them with two pull pins. For alkaline batteries, mount them with two 1/4-20 socket head cap screws and two 1/4" washers.
25. Move the cables from the payload bay wiring harness and the aft battery aside so as not to impede the tie rod when it is inserted into the payload bay tie rod guide tube.
26. Clean and inspect the aft hull O-rings and O-ring grooves and re-lubricate or replace as necessary.
27. Ensure that all of the connectors on the aft chassis are connected and seated properly.
28. Slide the aft section into the aft hull. Take care that the tie rod runs through the payload bay tie rod guide tube.

29. Press the aft endcap and the aft hull together, making sure the O-ring does not get pinched or otherwise damaged.
30. Make the connections from the aft battery to the mating connector on the glider aft chassis. If using lithium batteries, make the connections from the aft battery to the mating connector hanging from the port side of the main glider board.
31. Make the connections from the payload bay wiring harness to the mating connectors on the main glider board.



---

**NOTE** There may be other connectors that are specific to the glider. Connect these as appropriate.

---

32. Slide the aft section and hull together towards the payload bay. The tie rod will prevent the two sections from closing.
33. Using the 15 inch-pound torque T-handle, 24" extension and 3/16" hex bit, insert it into the vacuum seal port on the aft endcap and screw the tie rod into the forward section or add-on module tie rod receiver. The glider sections should come together smoothly and be tight and square to their mating sections. Make sure that the index marks on the hull sections are aligned and that the O-rings are not pinched or damaged. Tighten to 15 inch-pounds of torque.



---

**NOTE** If the hull sections are not tight, flex the glider by lifting or pressing on the tail fin tube to allow for further tightening.

---

34. Use a vacuum pump with the evacuation tool and the 3/16" torque handle assembly to evacuate the glider, sealing with the 7/16 x 20 PEEK MS plug. The glider should be evacuated to at least 6 inches Hg for a shallow glider and 7 inches Hg for a deep glider. However, it is best to pull a higher vacuum, as you can bleed some air in the when the glider is powered on. Tighten the plug to 15 inch-pounds of torque.



---

**CAUTION** PEEK parts are delicate. Proper tools must be used for PEEK parts and the proper torque applied, otherwise these parts may be damaged. In general, PEEK parts, such as the MS plug, can be recognized by their light brown color and plastic appearance.

---



---

**NOTE** The MS plug should be inspected for wear and replaced if worn.

---

35. After the glider is sealed, confirm and adjust the vacuum as needed (see "Checking and Setting the Vacuum on the Glider" on page 2-9).
36. Install the aft cowling (see "Aft Cowling" on page 2-54).
37. If necessary, re-install the wing rails on the payload bay.

## Checking and Setting the Vacuum on the Glider

Before applying power to the glider, verify that the glider is closed and has a proper vacuum. If the glider is not closed and does not have a proper vacuum, then follow these steps:

1. Assemble the glider as described in "Assembling the Glider" on page 2-5.
2. Remove the aft cowling as described in "Removing the Aft Cowling" on page 2-55.
3. Use a vacuum pump with the evacuation tool and the 3/16" torque handle assembly to evacuate the glider, sealing with the 7/16 x 20 PEEK MS plug. The glider should be evacuated to at least 6 inches Hg for a shallow glider and 7 inches Hg for a deep glider. However, it is best to pull a higher vacuum, as you can bleed some air in the when the glider is powered on. Tighten the plug to 15 inch-pounds of torque.
4. Once there is a proper vacuum and the MS plug is in place, apply the power. The glider then powers on and goes through its normal startup routine. To gain control of the glider, when you see:

```
SEQUENCE: About to run initial.mi on try 0. You have 120
seconds to type a control-C to terminate the sequence. The
control-P character immediately starts the mission. All other
characters are ignored.
```

type `ctrl-c` to display the GliderDOS prompt.

5. From the GliderDOS prompt, type `callback 30`. This hangs up the Iridium phone for 30 minutes. You can enter any value for callback from 1 to 30. Alternatively, you can type `use - iridium` to take the Iridium out of service until your testing is complete.
6. Type `lab_mode on`. This places the glider in lab mode and prevents the glider from running its default mission.



---

**NOTE** Never deploy a glider in `lab_mode`.

---

7. Type `ballast`. This deflates the air bladder, and sets the pitch motor and ballast pump to 0.



---

**NOTE** Never deploy a glider in `ballast`.

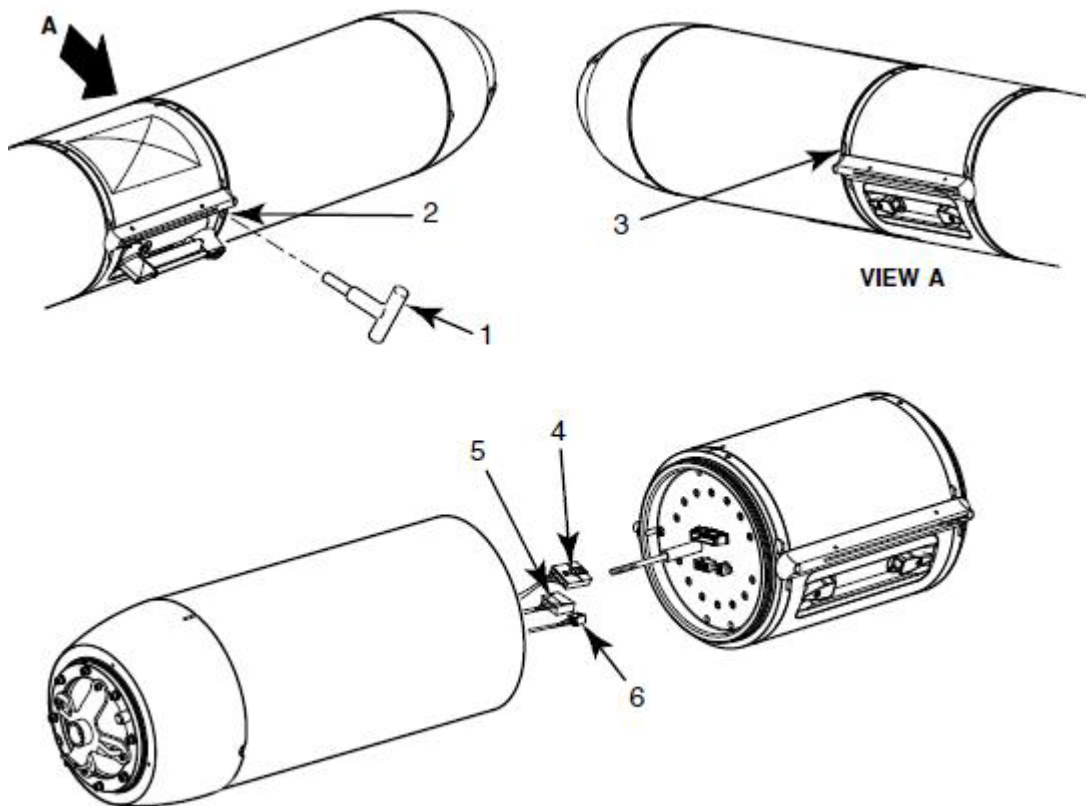
---

8. Wait for the prompt:  
Glider ready for ballasting.  
then type `report clearall`.
9. Type `report ++ m_vacuum`. This displays the vacuum inside the glider every time the sensor updates. If the vacuum is already at 6 inches Hg (7 inches Hg for 1000-meter) Hg, you are done (+/- .2). If not, you need to adjust the vacuum by allowing air in to decrease the value or pulling more air out to increase the value.
10. Once the vacuum is within 0.2 inches Hg of the target, type `report clearall`. This stops reporting the vacuum value.
11. If not in place already, install the aft cowling on the glider (see "Aft Cowling" on page 2-54). If you are connected via an external power supply, power down by typing `exit` before installing the cowling.
12. Install the Stop plug (red) as described in "Stop Plug (Red) and Go Plug (Green)" on page 2-52.

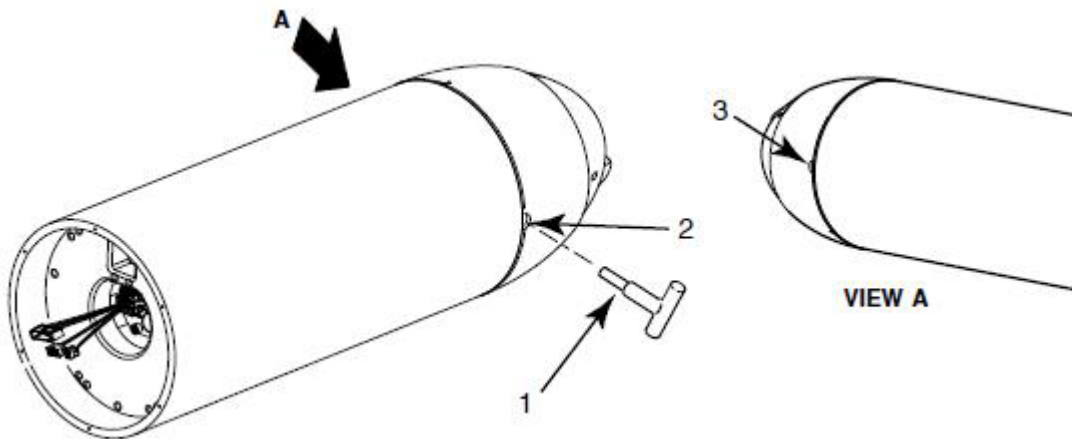
# Forward Assembly

Tools:	Hull separation tool
Materials and parts:	Forward assembly (shallow or deep)
Personnel required:	1 electronics technician
Equipment condition:	Glider is disassembled according to "Disassembling the Glider" on page 2-1.

## Removing the Forward Assembly



**Figure 2-2 Forward assembly (Shallow or Deep).**



**Figure 2-3 Forward assembly (Shallow or Deep).**

1. Using the hull separation tool (Figure 2-2, Item 1) at locations 2 and 3 in Figure 2-2, disengage the forward hull section from the forward assembly.
2. Disconnect the connectors (Figure 2-2, Items 4-6) from the payload bay.
3. Using the hull separation tool (Figure 2-3, Item 1) at locations 2 and 3 in Figure 2-3, disengage the forward hull section from the forward assembly.



**CAUTION** The forward and aft batteries are heavy and must be supported by the hulls in their respective bays at all times. If disassembly requires removing hulls or the assembly to which the battery is affixed, the batteries should be removed from the vehicle first, or conversely disconnected and left inside in the hulls while the assembly is removed and worked on.

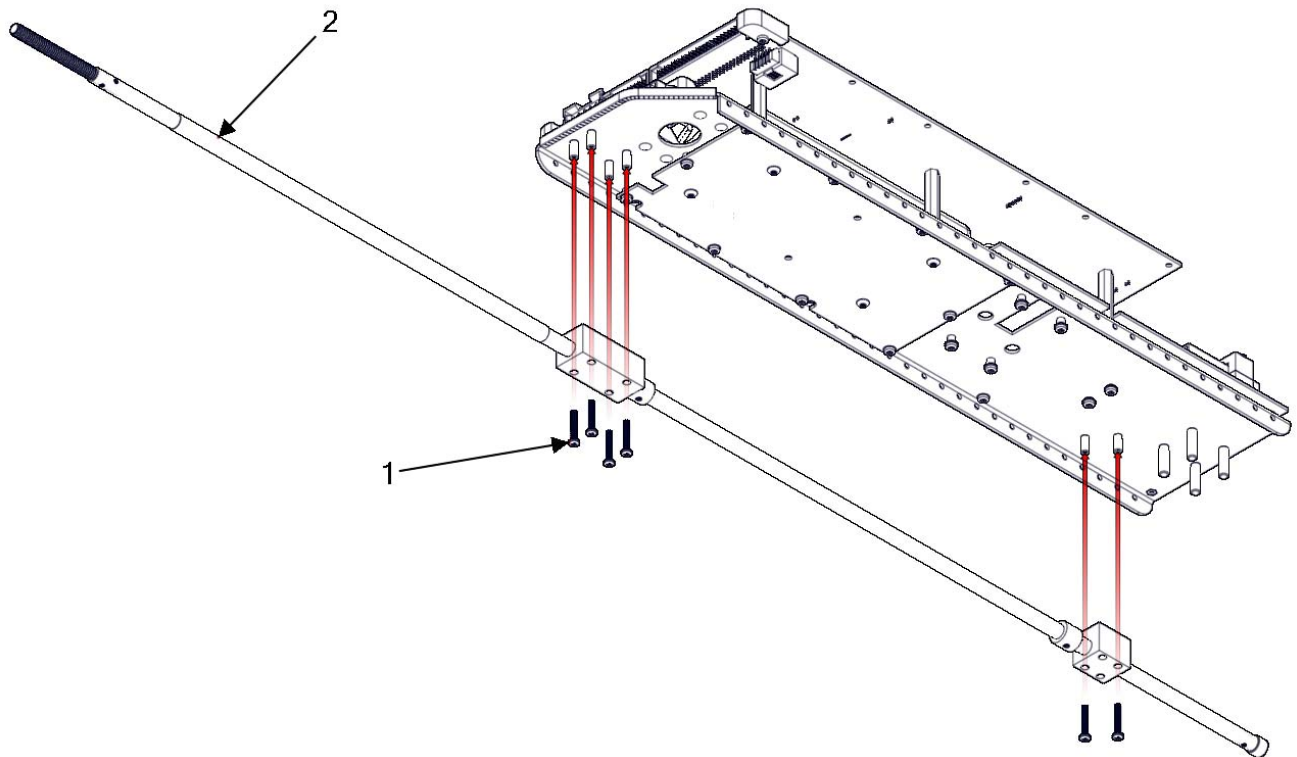
## Installing the Forward Assembly

1. Align the forward hull section with the forward assembly.
2. Connect the connectors (Figure 2-2, Items 4-6) from the forward assembly to the payload bay.
3. Align the forward assembly with the payload bay.
4. Reference "Assembling the Glider" on page 2-5 for the final installation.



# Tie Rod Assembly

Tools:	Phillips screwdriver
Materials and parts:	Tie rod assembly
Personnel required:	1 electronics technician
Equipment condition:	Glider is disassembled according to "Disassembling the Glider" on page 2-1.



**Figure 2-4 Tie rod assembly.**

## Removing the Tie Rod Assembly

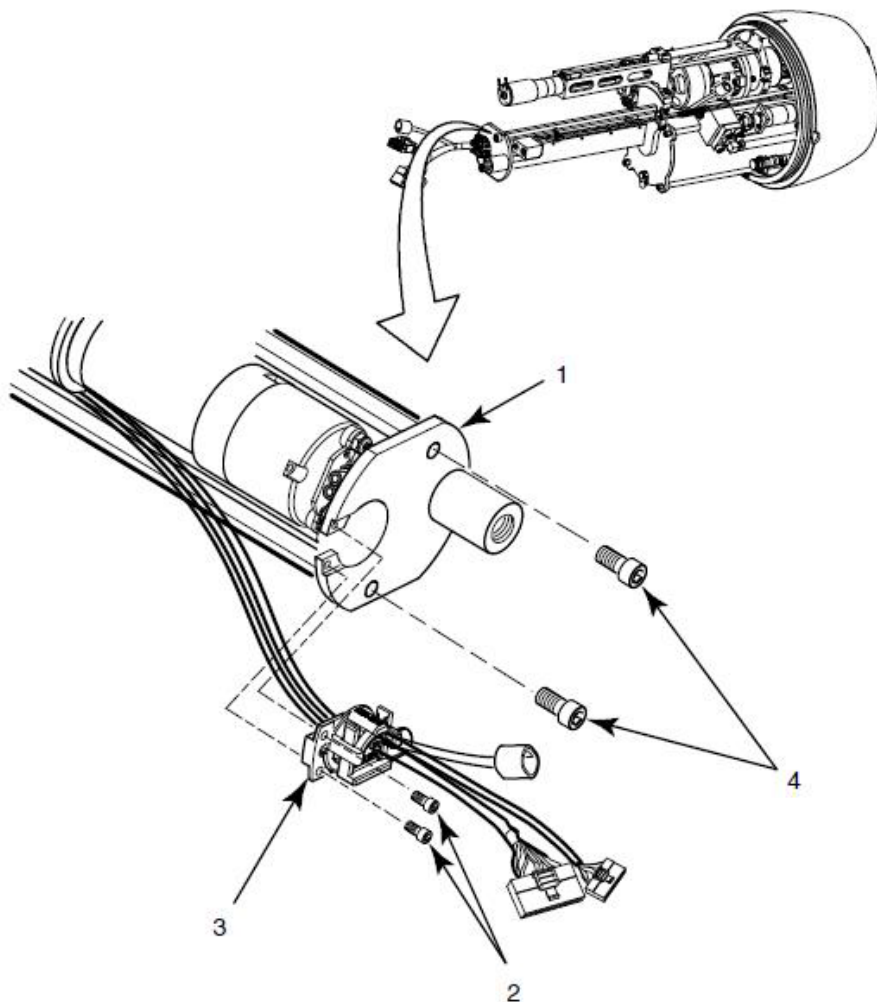
1. Remove the six screws (Figure 2-4, Item 1) that attach the tie rod (Figure 2-4, Item 2) to the bottom of the aft electronics tray.
2. Remove the tie rod (Figure 2-4, Item 2).

## Installing the Tie Rod Assembly

1. Position the tie rod assembly (Figure 2-4, Item 2) on the standoffs on the bottom of the aft electronics tray.
2. Place a drop of Loctite 243 (blue) on each of the six screws.
3. Install the six screws (Figure 2-4, Item 1) that attach the tie rod (Figure 2-4, Item 2) to the bottom of the aft electronics tray.

# Tie Rod Plate

Tools:	3/32" hex wrench 3/16" hex wrench
Materials and parts:	Tie rod plate
Personnel required:	1 electronics technician
Equipment condition:	Glider is disassembled according to "Disassembling the Glider" on page 2-1.



**Figure 2-5 Tie rod plate.**

## Removing the Tie Rod Plate

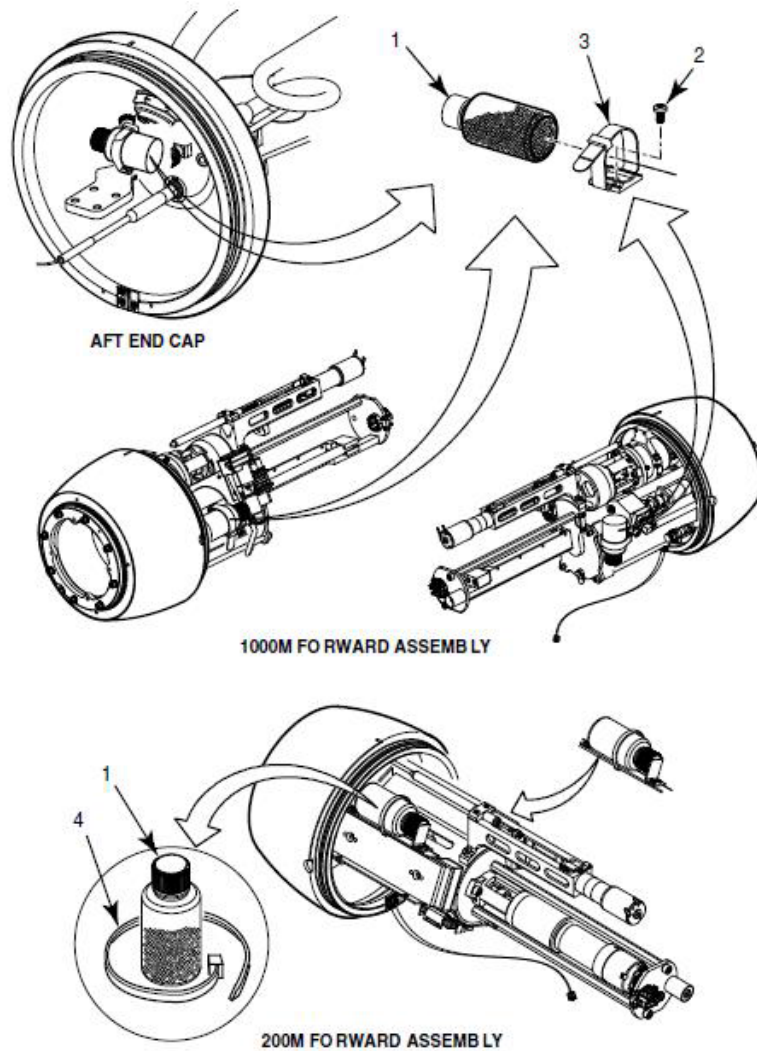
1. Remove the two screws (Figure 2-5, Item 2) that attach the ratcheting strain relief bushing (Figure 2-5, Item 3) to the tie rod plate (Figure 2-5, Item 1).
2. Remove the two tie rod plate screws (Figure 2-5, Item 4).

## Installing the Tie Rod Plate

1. Attach the tie rod plate with the two screws (Figure 2-5, Item 4).
2. Install the two screws (Figure 2-5, Item 2) that attach the ratcheting strain relief bushing (Figure 2-5, Item 3) to the tie rod plate (Figure 2-5, Item 1).

# Ballast Bottles

Tools:	Phillips screwdriver
Materials and parts:	Ballast bottle, 60 ML
Personnel required:	1 electronics technician
Equipment condition:	Glider is disassembled according to "Disassembling the Glider" on page 2-1.



**Figure 2-6 Ballast bottles, 60 ML.**



---

**NOTE** Moving and adjusting the ballast bottles will affect the glider's ballasting and H-moment. This should be done with care to maintain proper ballasting.

---



---

**CAUTION** An improperly ballasted glider may not fly well or can cause mission or vehicle failure.

---

## Removing the Ballast Bottles

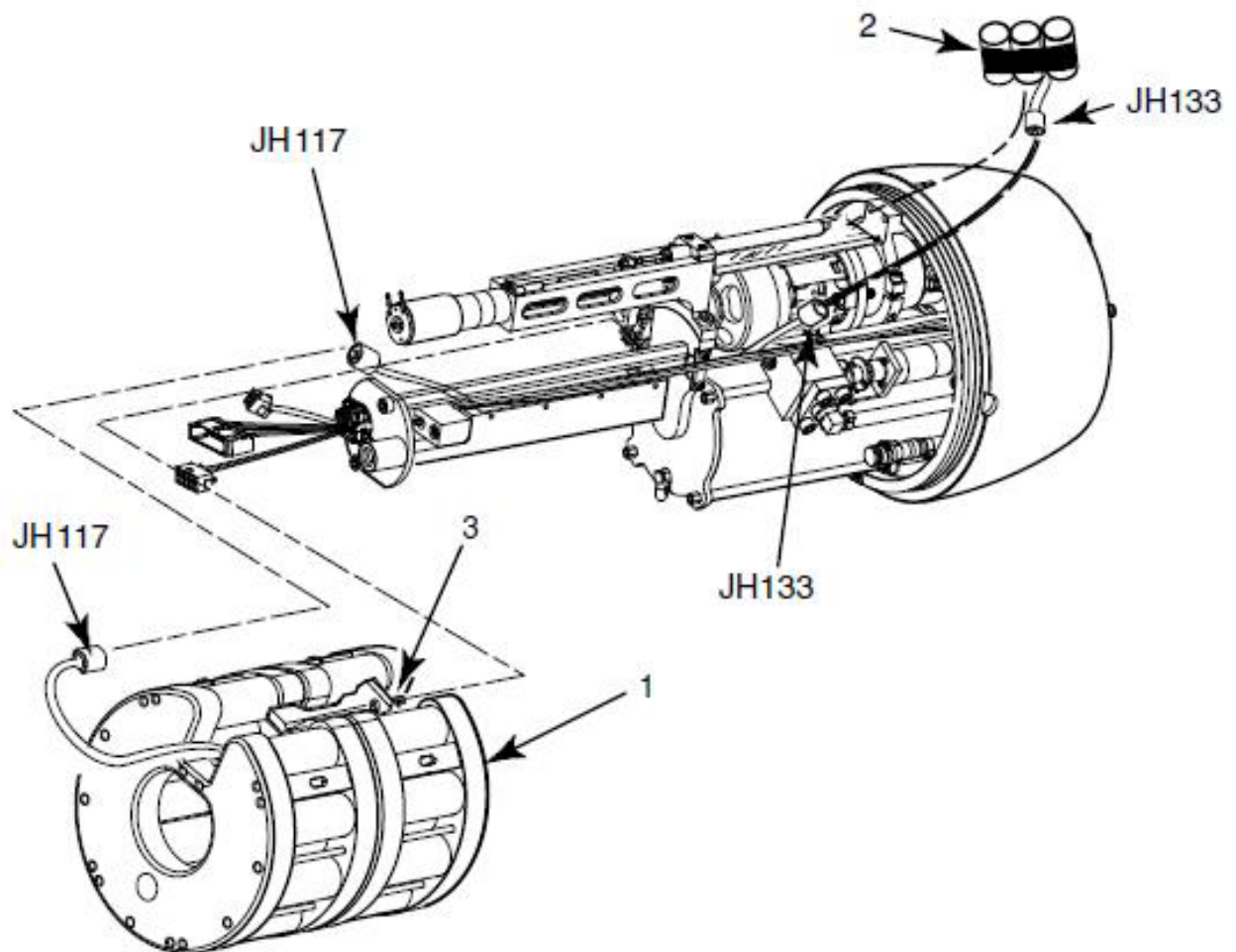
1. Loosen the ballast bottle bracket (Figure 2-6, Item 3) or the zip tie (Figure 2-6, Item 4).
2. Remove the ballast bottle (Figure 2-6, Item 1).
3. As necessary, remove the screw (Figure 2-6, Item 2) that secures the ballast bottle bracket (Figure 2-6, Item 3).

## Installing the Ballast Bottles

1. As necessary, install the screw (Figure 2-6, Item 2) that secures the ballast bottle bracket (Figure 2-6, Item 3).
2. Install the ballast bottle (Figure 2-6, Item 1).
3. Tighten the ballast bottle bracket (Figure 2-6, Item 3) or the zip tie (Figure 2-6, Item 4).

# Battery Pack

Tools:	5/32" x 12" red T-handle hex wrench
Materials and parts:	Glider battery pack
Personnel required:	1 electronics technician
Equipment condition:	Glider is disassembled according to "Disassembling the Glider" on page 2-1.



**Figure 2-7 Forward/pitch glider battery pack.**



---

**NOTE** Moving and adjusting the batteries will affect the glider's ballasting and H-moment. This should be done with care to maintain proper ballasting.

---



---

**CAUTION** An improperly ballasted glider may not fly well or can cause mission or vehicle failure.

---



---

**CAUTION** When installing new batteries, the `m_coulomb_amphr_total` sensor must be set to zero by typing `m_coulomb_amphr_total 0`.

---



---

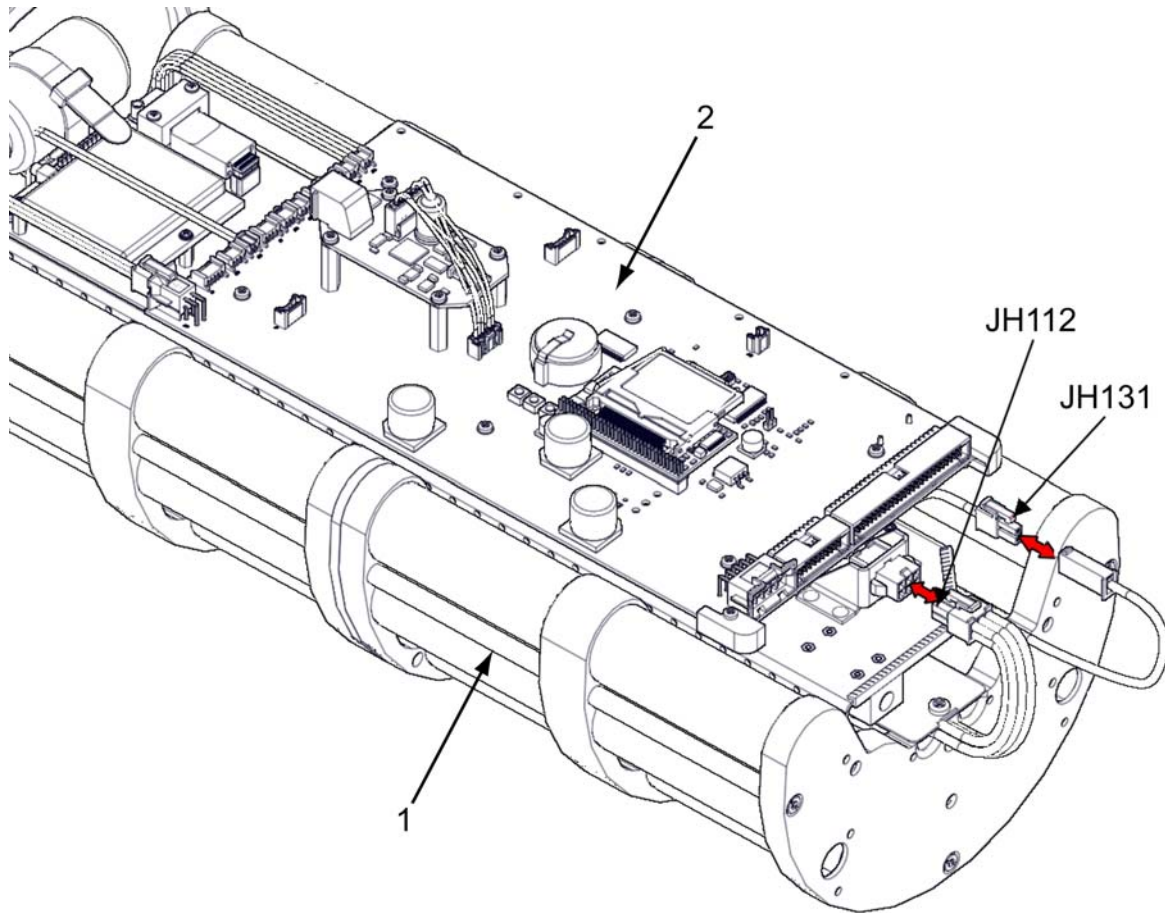
**WARNING** Lithium batteries pose a significant hazard when stored or handled improperly. The two hazards associated with lithium sulfuryl chloride batteries and their components are fire and explosion, which could occur if the batteries are crushed, punctured, excessively heated, charged, overdischarged, short circuited, or submerged in water in a non-waterproof enclosure.

Lithium sulfuryl chloride cells are safe to handle when all of their components are adequately wrapped and sealed within a stainless steel casing. When that casing is compromised, an immediate danger is present due to exposure of the contents (and byproducts of these contents) with their new environment. Lithium metal reacts with water to produce lithium hydroxide, a corrosive liquid and hydrogen gas, which is flammable. Sulfuryl chloride (the liquid cathode) is a corrosive liquid that reacts with water to produce hydrogen chloride gas (which is toxic and corrosive) and sulfuric acid, a corrosive liquid.

Remove your jewelry before handling lithium batteries. Wear the appropriate PPE—eye protection and chemical resistant gloves—while handling lithium batteries.

---





**Figure 2-8 Aft glider battery pack.**

## Removing the Glider Battery Pack

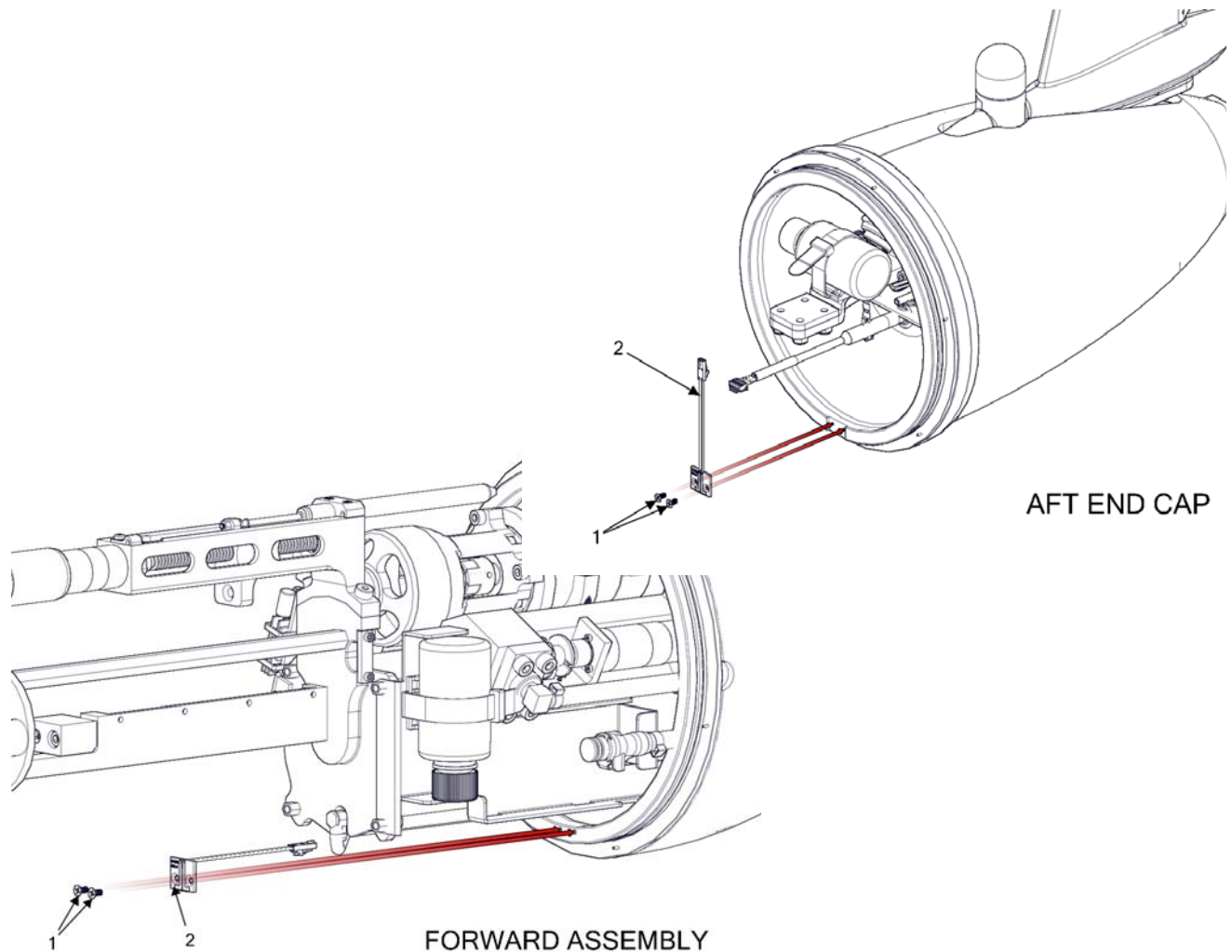
1. Unplug the JH117 connection on the pitch battery (Figure 2-7, Item 1) from the forward assembly.
2. Unplug the JH133 connection on the pitch battery (Figure 2-7, Item 2) from the forward assembly wiring harness.
3. Using the 5/32" x 12" red T-handle hex wrench, loosen the screw (Figure 2-7, Item 3).
4. Remove the pitch battery (Figure 2-7, Item 1).
5. Disconnect the JH112 connection on the aft battery (Figure 2-8, Item 1) from the aft electronics tray (Figure 2-8, Item 2).
6. Disconnect the JH131 connection on the aft battery (Figure 2-8, Item 1) from the aft electronics tray (Figure 2-8, Item 2).
7. Remove the aft battery.

## Installing the Glider Battery Pack

1. Position the aft battery and connect the JH131 and JH112 from the aft battery (Figure 2-8, Item 1) to the aft electronics tray (Figure 2-8, Item 2).
2. For lithium batteries, mount them with two pull pins. For alkaline batteries, mount them with two 1/4-20 socket head cap screws and two 1/4" washers.
3. Position the pitch battery (Figure 2-7, Item 1) and tighten the screw (Figure 2-7, Item 3).
4. Connect JH133 on the pitch battery (Figure 2-7, Item 2) to the forward assembly wiring harness.

# Leak Detect Assembly

Tools:	Phillips screwdriver
Materials and parts:	Leak detect assembly
Personnel required:	1 electronics technician
Equipment condition:	Glider is disassembled according to "Disassembling the Glider" on page 2-1.



**Figure 2-9 Leak detect assembly.**

## Removing the Leak Detect Assembly

1. Unscrew the two screws (Figure 2-9, Item 1) from either the forward assembly or aft end cap.
2. Unplug the leak detect assembly (Figure 2-9, Item 2) from either the forward assembly or aft end cap.
3. Remove the leak detect assembly (Figure 2-9, Item 2).

## Installing the Leak Detect Assembly

1. Place the leak detect assembly (Figure 2-9, Item 2) in position on either the forward assembly or aft end cap.
2. Install the two screws (Figure 2-9, Item 1) to either the forward assembly or aft end cap.

# Recovery Assembly

Tools:

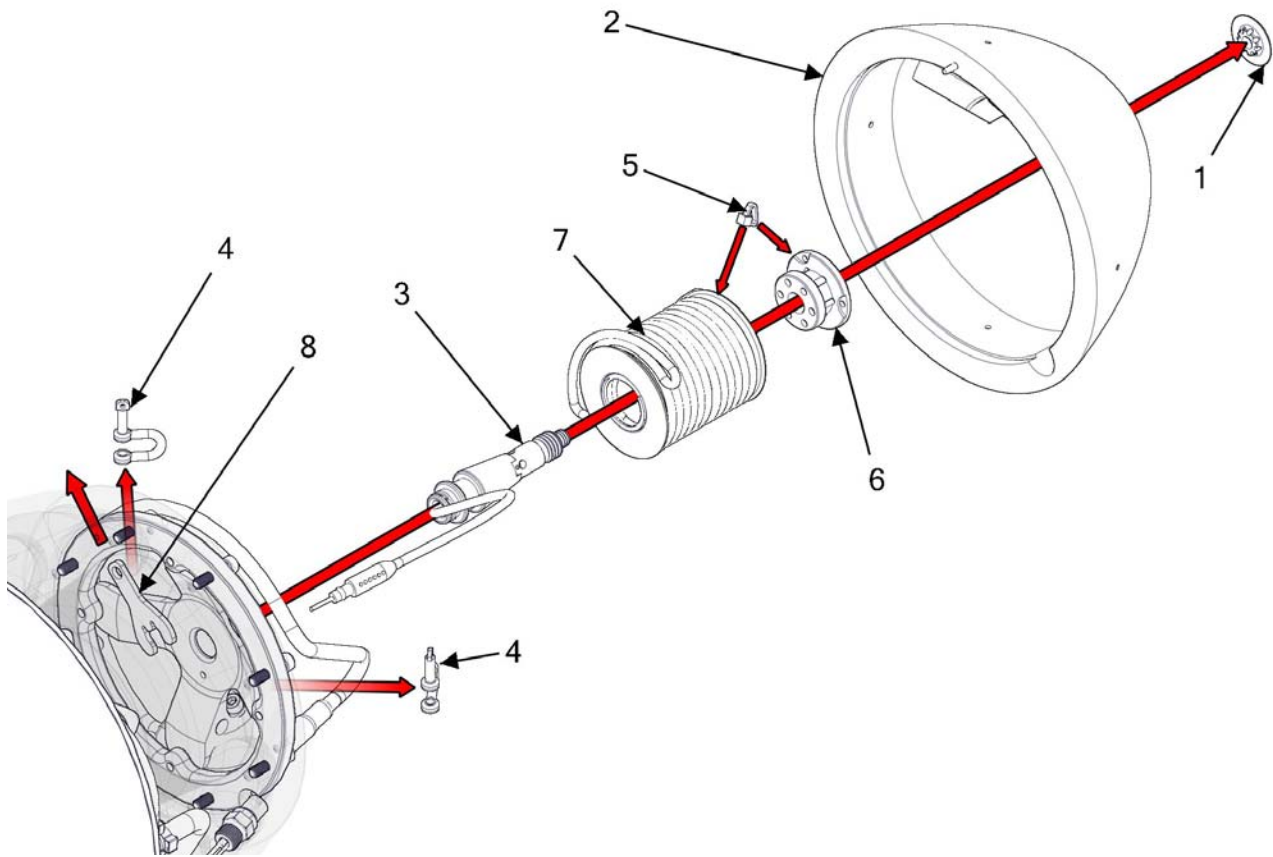
Snap-ring pliers  
Phillips screwdriver

Materials and parts:

Recovery assembly

Personnel required:

1 electronics technician



**Figure 2-10 Recovery assembly.**

## Removing the Recovery Assembly

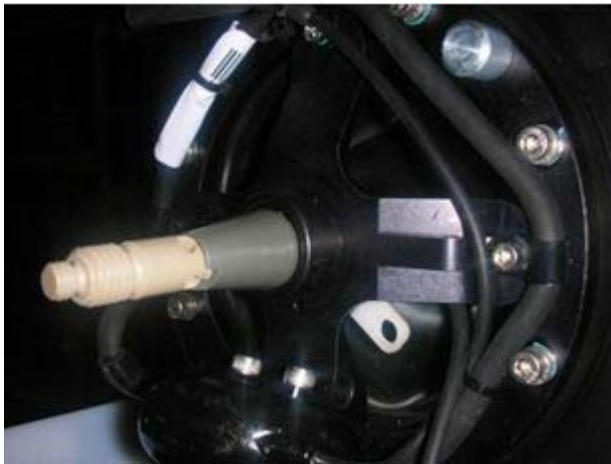
1. Ensure the red plug is installed.
2. Remove the sonar dome vent washer (Figure 2-10, Item 1).
3. Remove the buoyant sonar dome assembly (Figure 2-10, Item 2).
4. Remove the zip tie (Figure 2-10, Item 5).
5. Unscrew the spool nut (Figure 2-10, Item 6).
6. Remove the shackles (Figure 2-10, Item 4) from the recovery spool base.
7. Remove the recovery spool assembly with line (Figure 2-10, Item 7).
8. Remove the retention clip (Figure 2-10, Item 8).
9. Disconnect the nose release cartridge (Figure 2-10, Item 3) connector from the altimeter.

## Installing the Recovery Assembly

1. Feed the nose release cartridge wire (Figure 2-10, Item 3) through the center of the recovery spool base, and feed the connector back out at 4 o'clock position.



2. Install the retention clip (Figure 2-10, Item 8) onto the nose release cartridge under the recovery spool base at the 4 o'clock position. Rotate the nose release cartridge so that the center tab on the retention clip aligns with and inserts into the slot on the cartridge base.



3. Connect the nose release cartridge connector to the altimeter, and secure the wire with nylon cable ties. Secure the wire to the hole on the end of the retention clip tab with a cable tie.



**NOTE** Make sure the cut (sharp) end of the cable tie faces away from the ballast pump. Otherwise, the sharp end of the cable ties may puncture the ballast pump's bladder.



4. Slide the recovery spool assembly with line (Figure 2-10, Item 7) over the nose release cartridge (Figure 2-10, Item 3).





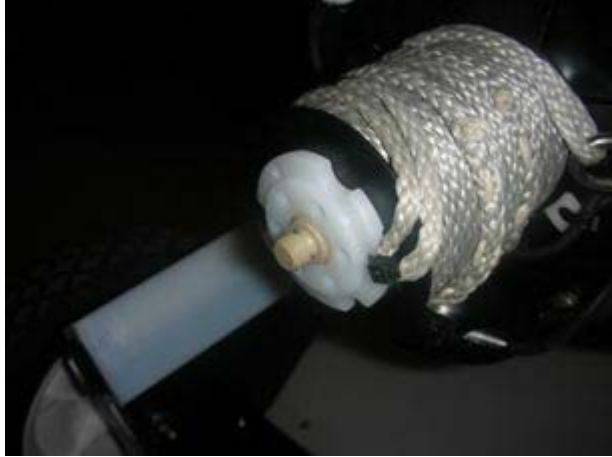
5. Slide the spool assembly with a line (Figure 2-10, Item 7) over the nose release cartridge (Figure 2-10, Item 3). Tighten the spool nut (Figure 2-10, Item 6) to the nose release cartridge until it is flush with the end of the large threads. The spool should rotate easily.



6. Install the end loop of the line closest to the base through *both* shackles. (Figure 2-10, Item 4).
7. Attach the shackles to the recovery spool base.



8. Attach a cable tie to the spool nut and the forward loop on the recovery spool. Tighten the zip tie to secure the line to the spool nut (Figure 2-10, Item 5). Hold the spool nut, and rotate the spool to take up any excess slack in the recovery line.



9. Remove the rubber band or other device securing the line during shipping.



---

**CAUTION** Failure to remove the rubber band or other device securing the line could result in the line recovery system's failure.

---

10. Attach the buoyant sonar dome assembly (Figure 2-10, Item 2) (with flotation foam and index pin on top) to the release cartridge assembly with the sonar dome vent washer (Figure 2-10, Item 1). Use long-nose pliers to tighten.





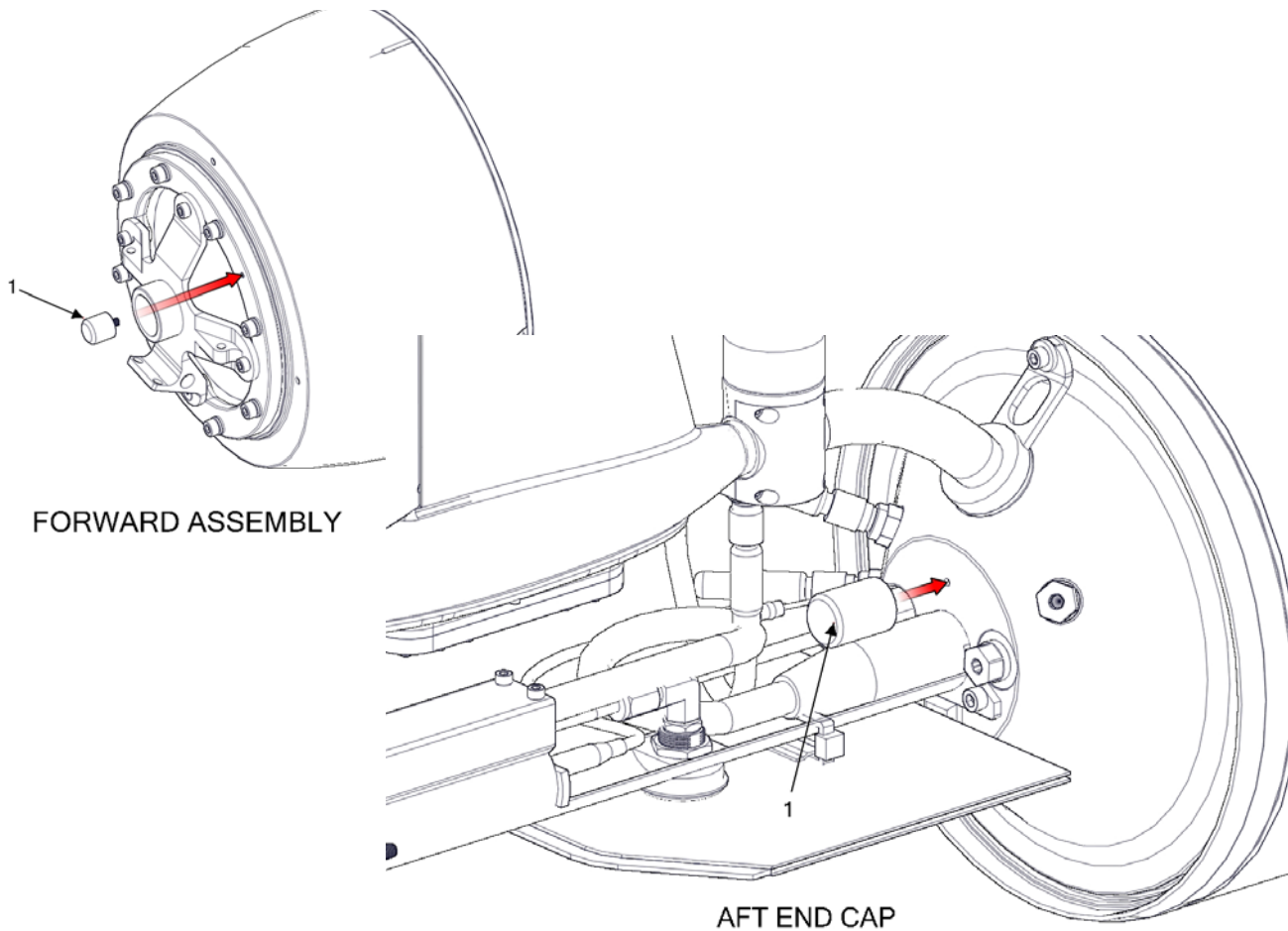
---

**NOTE** If the buoyant sonar dome assembly will not move into the proper position, reposition the zip ties that are securing the wire harness.

---

# Anode Assembly

Tools:	Digital voltage detector with two leads Pliers 10-inch-pound anode installation torque wrench 3/16" hex wrench
Materials and parts:	Anode assembly
Personnel required:	1 electronics technician
Equipment condition:	Glider is disassembled according to "Disassembling the Glider" on page 2-1, "Removing the Recovery Assembly" on page 2-26.



**Figure 2-11 Anode assembly.**

## Removing the Aft/Forward Anode Assembly

Using a pair of pliers, grasp the anode assembly and unscrew it from the glider.



---

**CAUTION** Do not apply any threadlock compound, such as Loctite, to the threads of the anode assembly. The threadlock compound affects the electrical conductivity, which would prevent the anode from operating properly.

---

## Installing the Aft Anode Assembly

1. Screw the 6-32 x 1/2" set screw into the 3/4" x 1" zinc anode, leaving approximately 1/4" of the set screw outside of the anode.
2. Place the O-ring over the set screw at the base of the anode.
3. Screw the anode assembly into the aft end cap by hand.
4. Slip the anode drive socket over the anode and tighten the cap screw using the 3/16" hex wrench.
5. Torque the anode assembly to 10 inch-pounds.



---

**NOTE** Over tightening the anode may strip the anode's interior threads, rendering it useless.

---

6. If no torque wrench is available, tighten the anode just beyond finger tight.
7. Using a digital ohmmeter, ensure that there is electrical continuity between the center of the anode and either ejection weight tube mounting screw (Figure 2-11, Item 2).



---

**NOTE** Three different sizes of anode are available. The appropriate size used should be based on the deployment length and the corrosiveness of the water. If even larger sacrificial anodes are required, the aft anode assembly can be tapped, and another anode can be screwed into the back of it.

---

## Installing the Forward Anode Assembly

1. Screw the 6-32 x 1/2" set screw into the 1/2" x 1/2" zinc anode, leaving approximately 1/4" of the set screw outside of the anode.
2. Place the O-ring over the set screw at the base of the anode.
3. Screw the anode assembly into the aft end cap by hand.
4. Slip the anode drive socket over the anode and tighten the cap screw using the 3/16" hex wrench.
5. Torque the anode assembly to 10 inch-pounds.



---

**NOTE** Over tightening the anode may strip the anode's interior threads, rendering it useless.

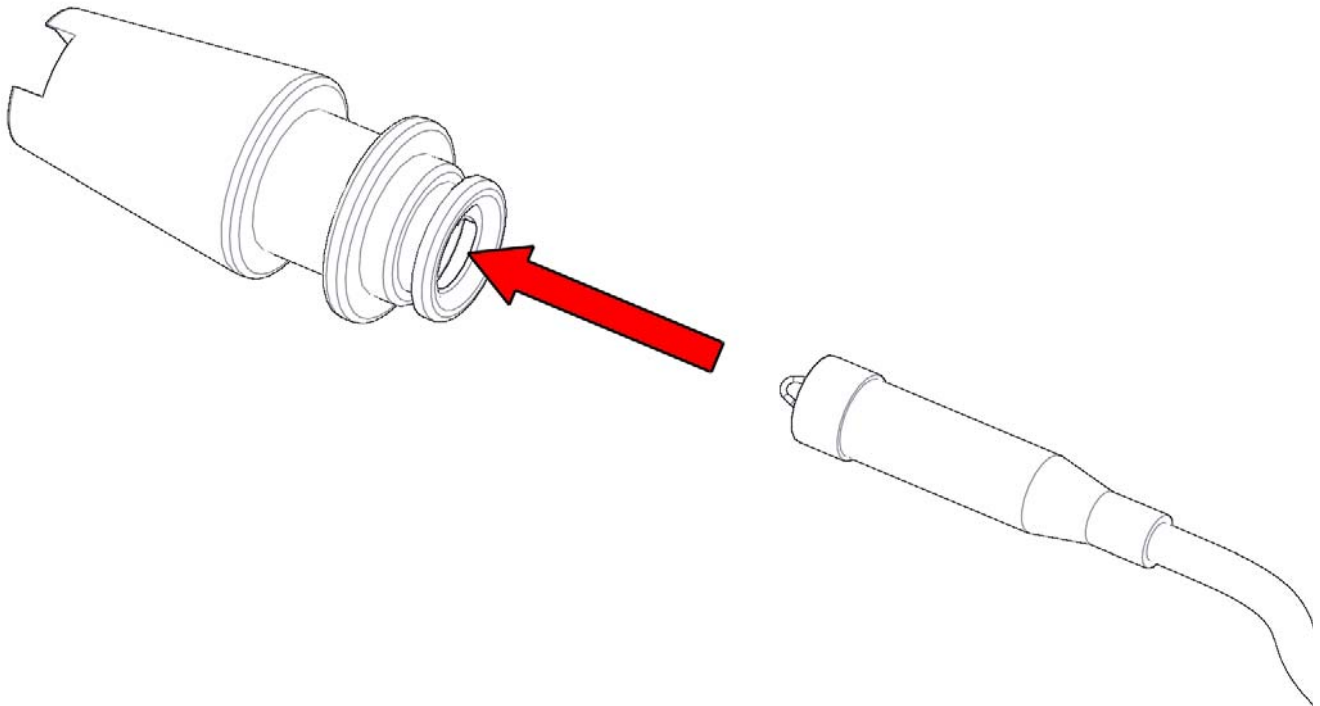
---

6. If no torque wrench is available, tighten the anode just beyond finger tight.
7. Using a digital ohmmeter, ensure that there is electrical continuity between the center of the anode and either ejection weight tube mounting screw (Figure 2-11, Item 2).

# Installing the Recovery Cartridge Assembly

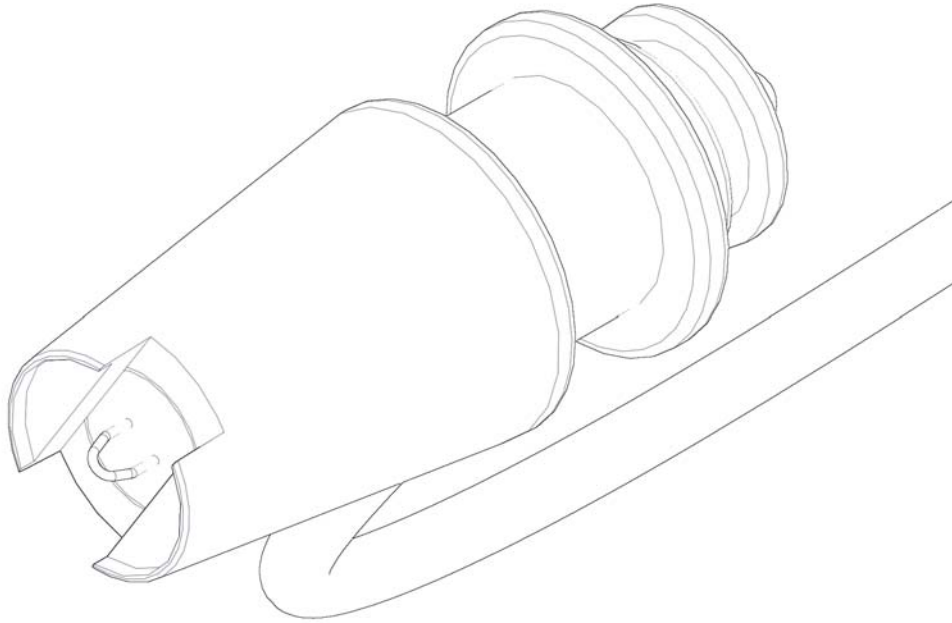
Tools:	Wire cutters
Materials and parts:	Cartridge assembly and monofilament
Personnel required:	1 electronics technician
Equipment condition:	Glider is disassembled according to "Disassembling the Glider" on page 2-1.

1. Align the burn-wire bushing assembly with the metal release housing. Then feed the burn-wire bushing assembly into the metal release housing (Figure 2-12 and Figure 2-13).

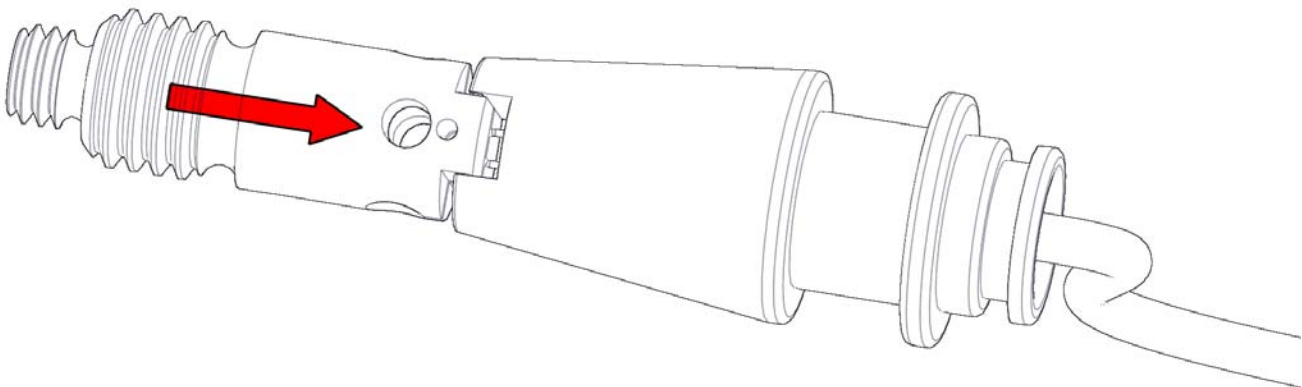


**Figure 2-12 Feeding the burn wire assembly into the metal release housing.**

2. Slide the threaded PEEK stud over the wire loop and into the release housing (Figure 2-14).



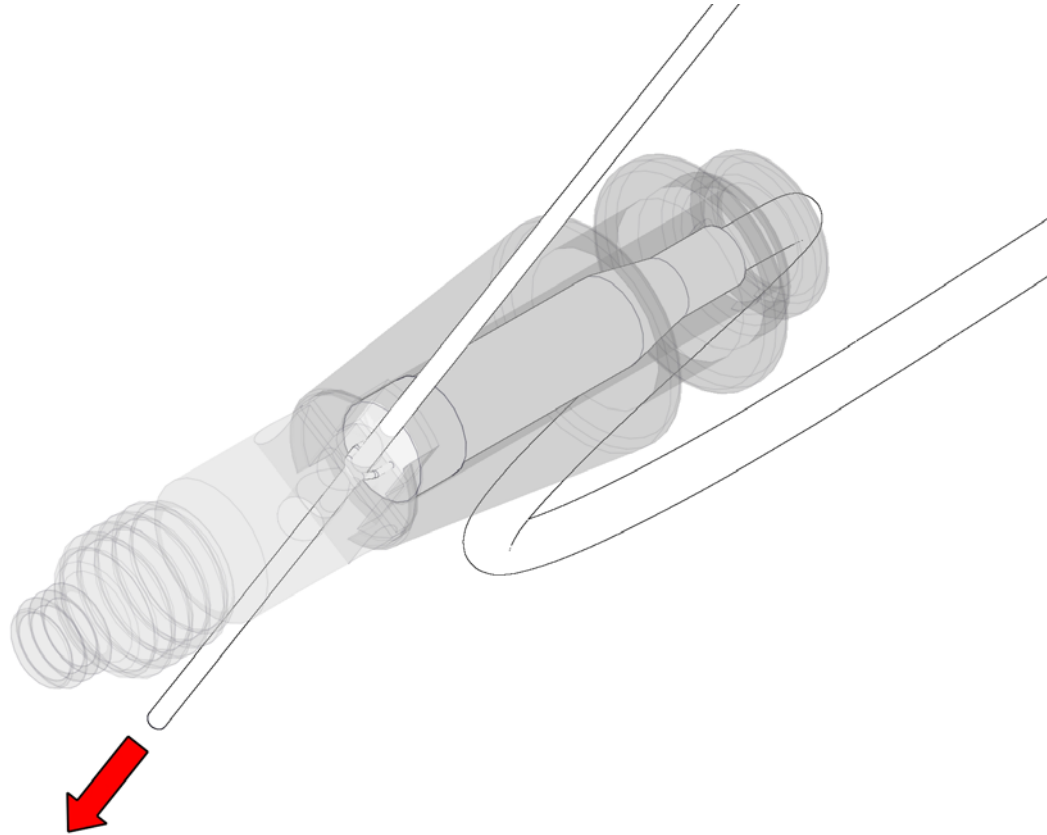
**Figure 2-13 Release housing.**



**Figure 2-14 Sliding the threaded PEEK stud into the release housing.**

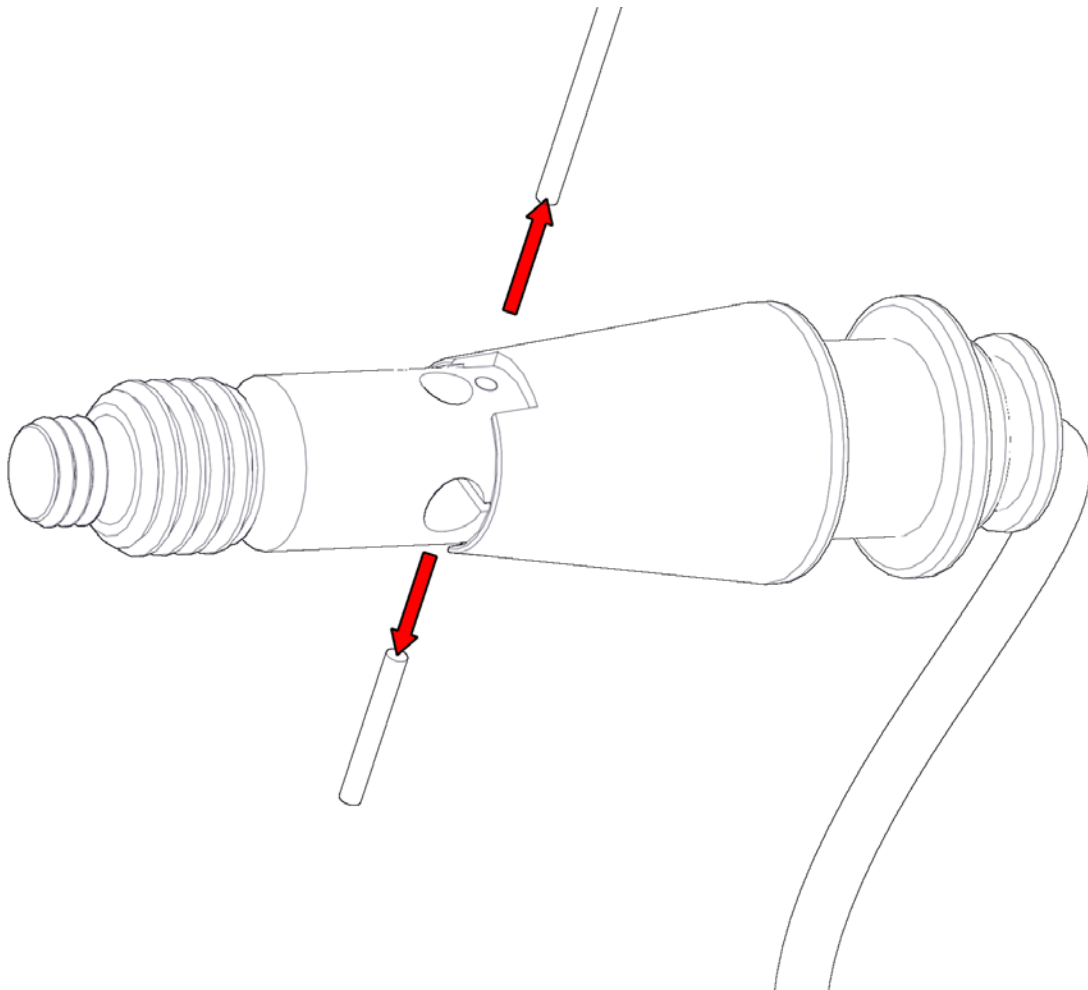


3. Feed a long sharpened piece of monofilament through the small hole in the threaded stud, under the wire loop, and out of the other side of the threaded stud. Pull the monofilament through until it stops at the cut end (Figure 2-15).



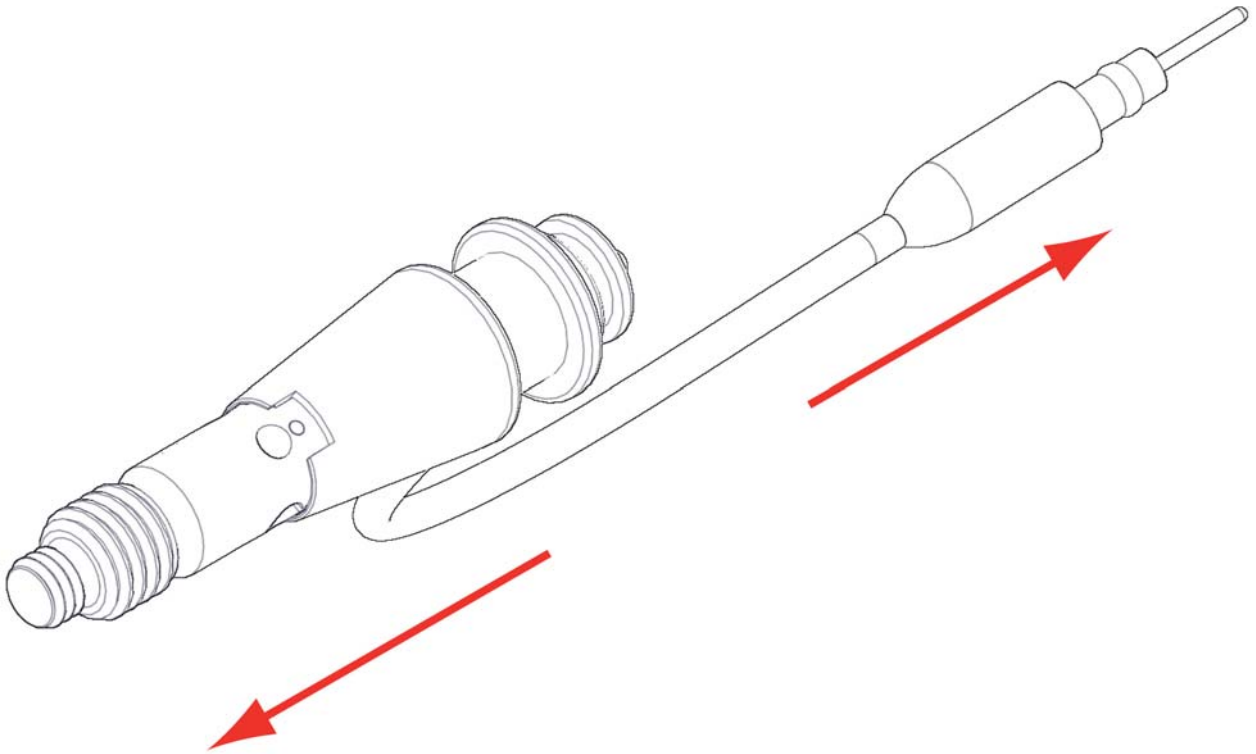
**Figure 2-15 Feeding the monofilament.**

4. Trim the long end of the monofilament flush to the release housing (Figure 2-16).



**Figure 2-16** *Trimming the monofilament.*

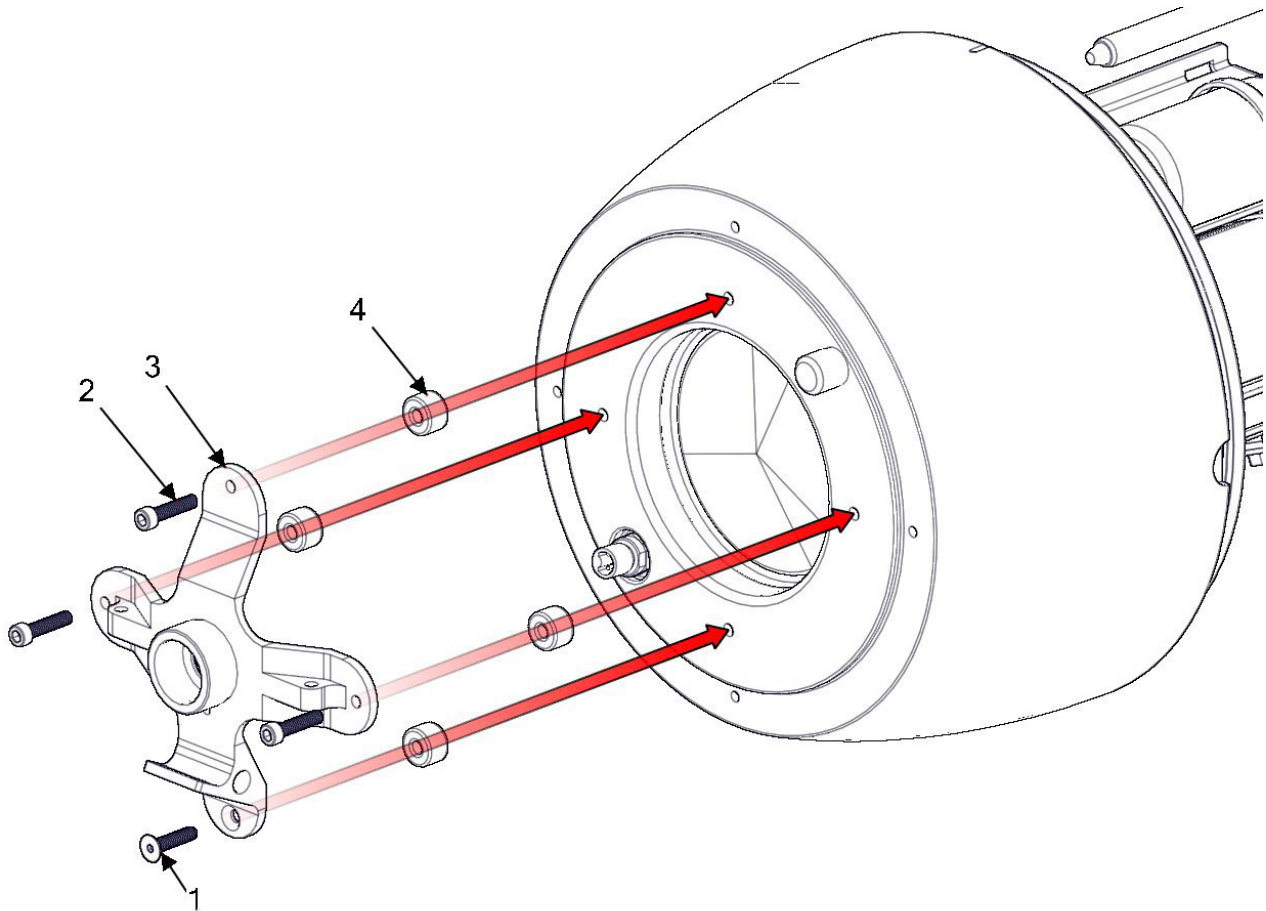
5. Ensure that the release housing and the threaded stud are securely fastened by attempting to pull them apart (Figure 2-17). They should be attached firmly and not come free.



**Figure 2-17** *Pulling apart the release housing and threaded stud.*

# Recovery Spool Base

Tools:	9/64" hex wrench 3/32" hex wrench
Materials and parts:	Recovery spool base (shallow or deep)
Personnel required:	1 electronics technician
Equipment condition:	Glider is disassembled according to "Disassembling the Glider" on page 2-1, "Removing the Recovery Assembly" on page 2-26 and "Removing the Altimeter Transducer Assembly" on page 2-44.



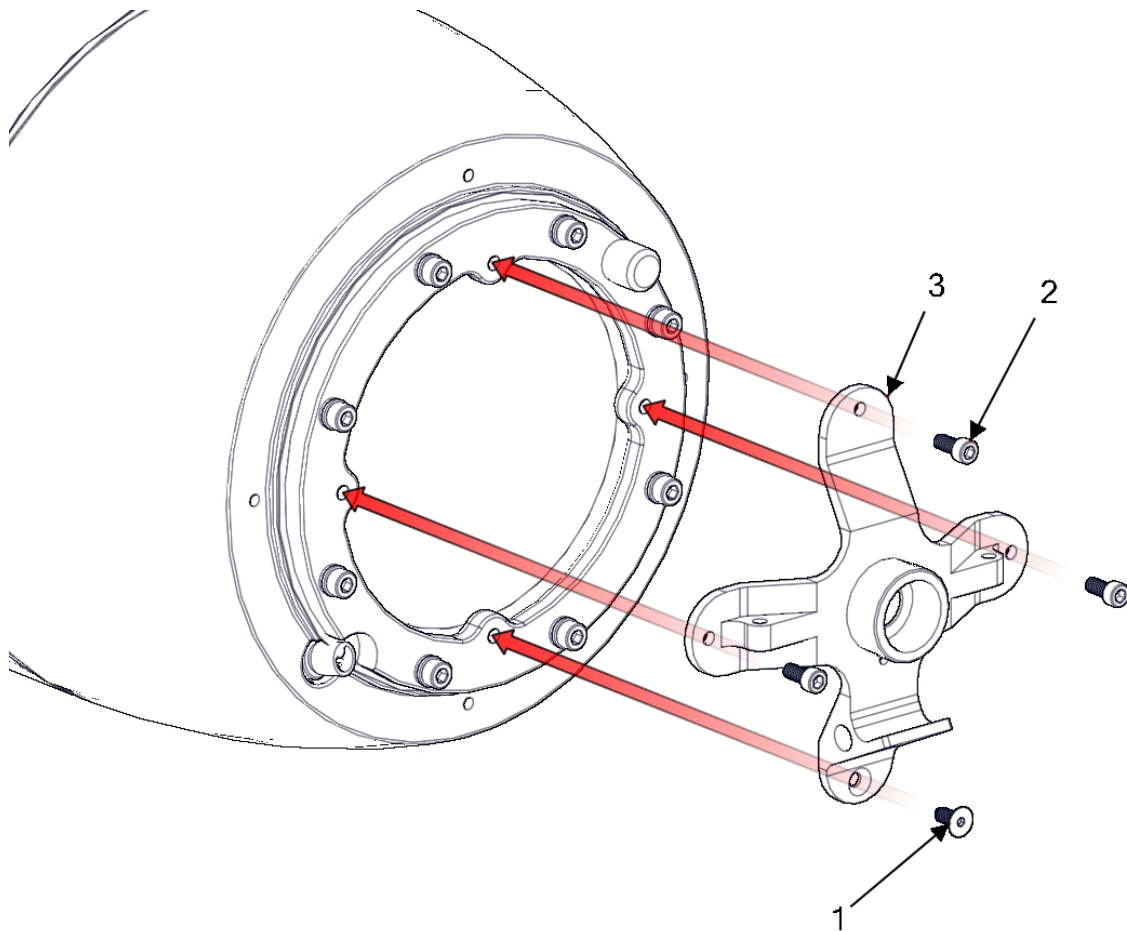
**Figure 2-18 Recovery spool base.**

## Removing the 200-meter Recovery Spool Base

1. Remove the single screw (Figure 2-18, Item 1).
2. Remove the three screws (Figure 2-18, Item 2).
3. Remove the recovery spool base (Figure 2-18, Item 3).
4. Remove the four spacers (Figure 2-18, Item 4).

## Removing the 1000-meter Recovery Spool Base

1. Remove the single screw (Figure 2-19, Item 1).
2. Remove the three screws (Figure 2-19, Item 2).
3. Remove the recovery spool base (Figure 2-19, Item 3).



**Figure 2-19 Recovery spool base (1000-meter).**

## Installing the 200-meter Recovery Spool Base

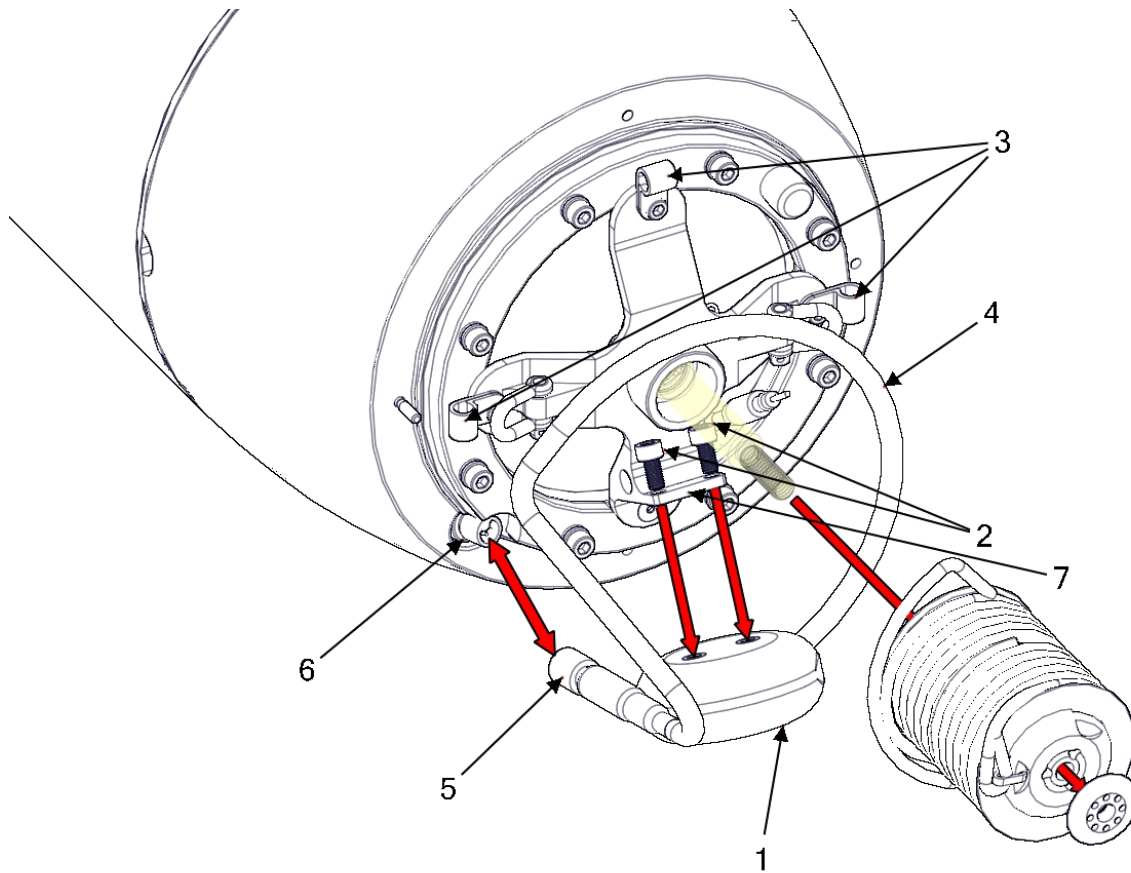
1. Position the recovery spool base (Figure 2-18, Item 3) on four spacers (Figure 2-18, Item 4).
2. Install the three screws (Figure 2-18, Item 2).
3. Install the single screw (Figure 2-18, Item 1).

## Installing the 1000-meter Recovery Spool Base

1. Position the recovery spool base (Figure 2-19, Item 3).
2. Install the three screws (Figure 2-19, Item 2).
3. Install the single screw (Figure 2-19, Item 1).

# Altimeter Transducer Assembly

Tools:	9/64" hex wrench 5/32" hex wrench
Materials and parts:	Altimeter transducer assembly
Personnel required:	1 electronics technician
Equipment condition:	Glider is disassembled according to "Removing the Recovery Assembly" on page 2-26.



**Figure 2-20** Altimeter transducer assembly.

## Removing the Altimeter Transducer Assembly

1. Remove the recovery assembly according to "Removing the Recovery Assembly" on page 2-26.
2. Remove the two screws (Figure 2-20, Item 2) from the altimeter transducer (Figure 2-20, Item 1).
3. Unscrew the plastic clips (Figure 2-20, item 3) that secure the altimeter cable pigtail (Figure 2-20, item 4) to the bulkhead.
4. Disconnect the cable connector (Figure 2-20, item 5) located at the end of the altimeter cable from the bulkhead connector (Figure 2-20, item 6).

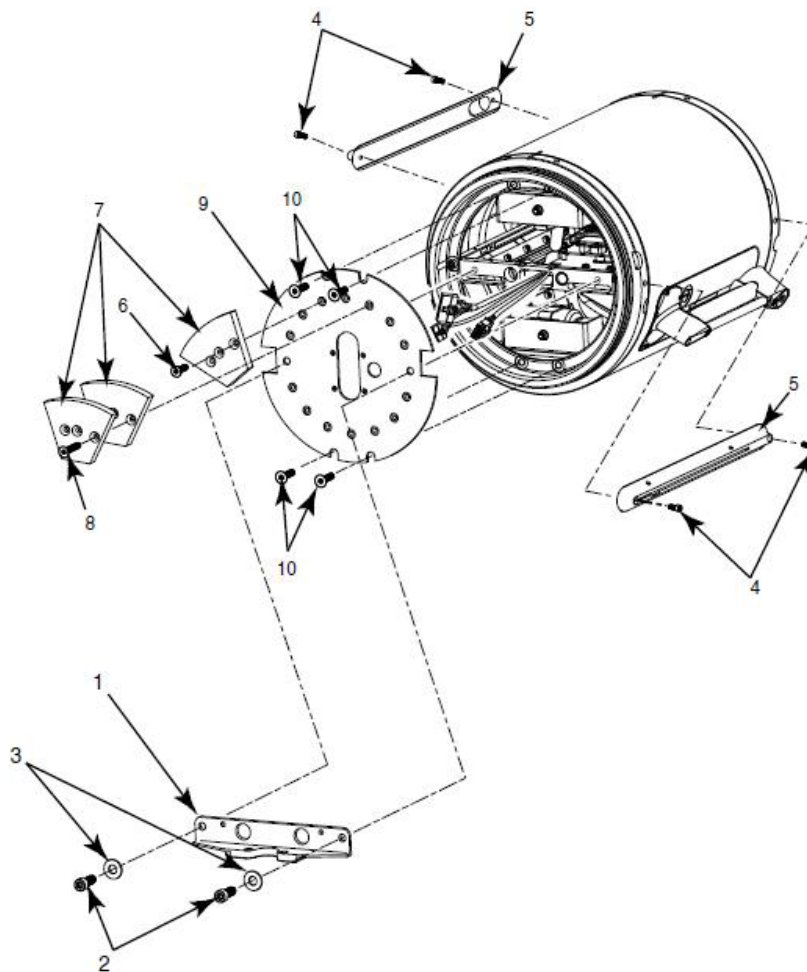
## Installing the Altimeter Transducer Assembly

1. Screw the cable connector (Figure 2-20, item 5) located at the end of the altimeter cable into the bulkhead connector (Figure 2-20, item 6).
2. Secure the altimeter cable pigtail (Figure 2-20, item 4) to the bulkhead by inserting the pigtail into the plastic clips (Figure 2-20, item 3) on the bulkhead and screwing the clips shut.
3. Install the 2 screws (Figure 2-20, item 2) through the recovery spool base (Figure 2-20, item 7) and into the altimeter transducer (Figure 2-20, item 1).
4. Install the recovery assembly according to "Installing the Recovery Assembly" on page 2-27.



# Payload Bay Assembly

Tools:	Phillips screwdriver
Materials and parts:	Payload bay assembly
Personnel required:	1 electronics technician
Equipment condition:	Glider is disassembled according to "Disassembling the Glider" on page 2-1.



**Figure 2-21 Payload bay assembly.**

## Removing the Payload Bay Guard Plate



---

**CAUTION** If the roll weights are repositioned or replaced, ballasting should be validated.

---

1. Remove the aft payload bay guard plate (Figure 2-21, Item 9) from the payload bay by removing the two screws (Figure 2-21, Item 2) and the battery mount bracket (Figure 2-21, Item 1).



---

**NOTE** With the screws (Figure 2-21, Item 2) removed, the aft battery receiver bracket (Figure 2-21, Item 1) will be unattached and must be retained.

---

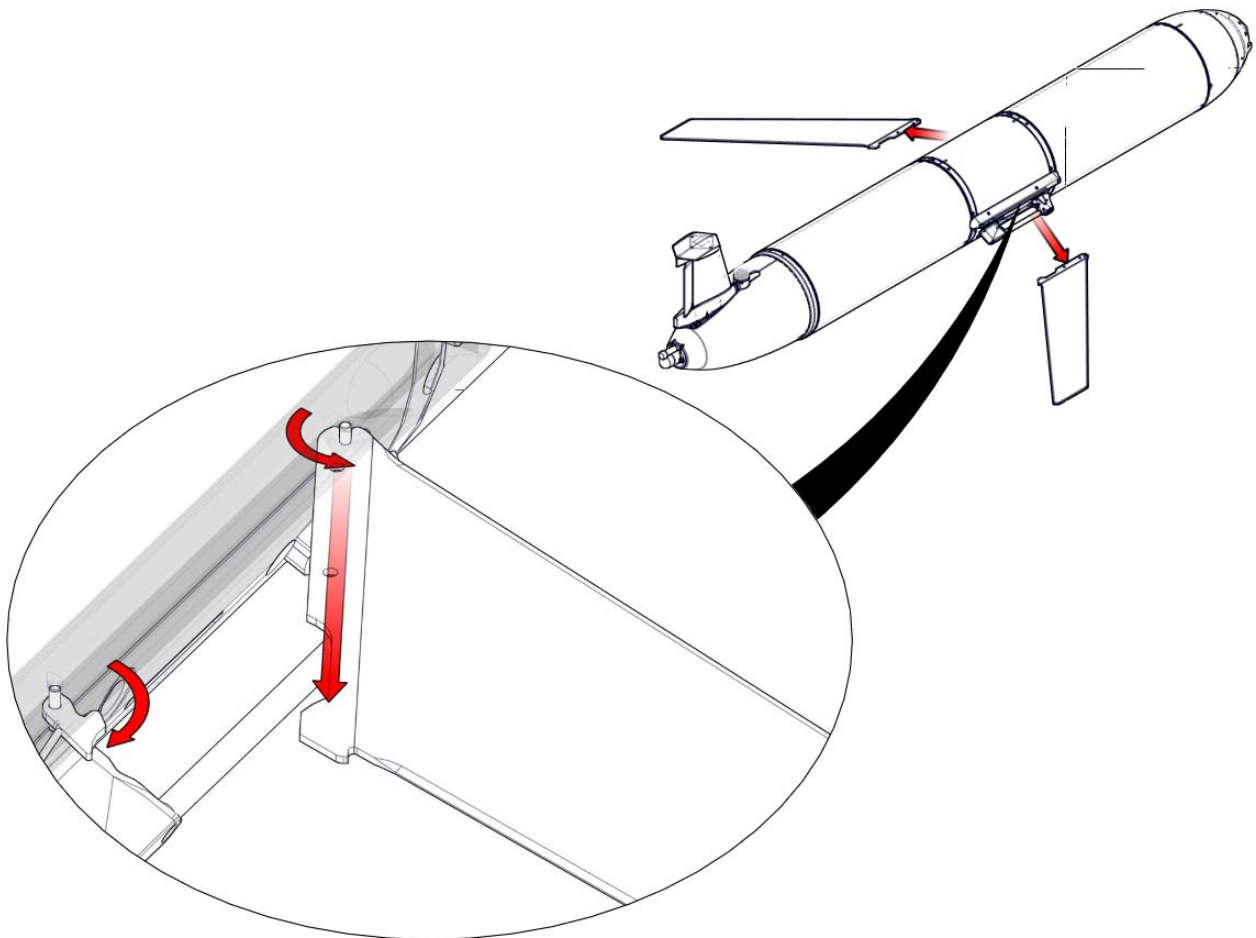
2. If using one roll weight (Figure 2-21, Item 7), remove one screw (Figure 2-21, Item 6).
3. If using three roll weights (Figure 2-21, Item 7), remove one screw (Figure 2-21, Item 8).
4. Remove the four screws (Figure 2-21, Item 4) from the snap-in wing support (Figure 2-21, Item 5).
5. Remove the snap-in wing support (Figure 2-21, Item 5).

## Installing the Payload Bay Guard Plate

1. If using one roll weight (Figure 2-21, Item 7), install one screw (Figure 2-21, Item 6).
2. If using three roll weights (Figure 2-21, Item 7), install one screw (Figure 2-21, Item 8).
3. Place the snap-in wing support (Figure 2-21, Item 5) in position on the payload bay.
4. Install the snap-in wing support (Figure 2-21, Item 5) with four screws (Figure 2-21, Item 4).
5. Paying attention to the center line marks, slide the payload hull section over the payload bay and seat squarely on the front O-ring. Use caution to prevent damage to the payload sensors.
6. Install the aft payload bay guard plate (Figure 2-21, Item 9) to the payload bay by inserting the two screws (Figure 2-21, Item 2) and two washers (Figure 2-21, Item 3), through the aft battery receiver bracket (Figure 2-21, Item 1) and into the aft payload bay guard (Figure 2-21, Item 9). Do not over tighten.
7. Install the four screws (Figure 2-21, Item 10) to the aft payload bay guard (Figure 2-21, Item 9).

# Wings

Tools:	None
Materials and parts:	Wings
Personnel required:	1 electronics technician



**Figure 2-22 Wings.**

## Removing the Wings



---

**CAUTION** Take care when removing the wings, as they are not buoyant and will sink if dropped in water.

---

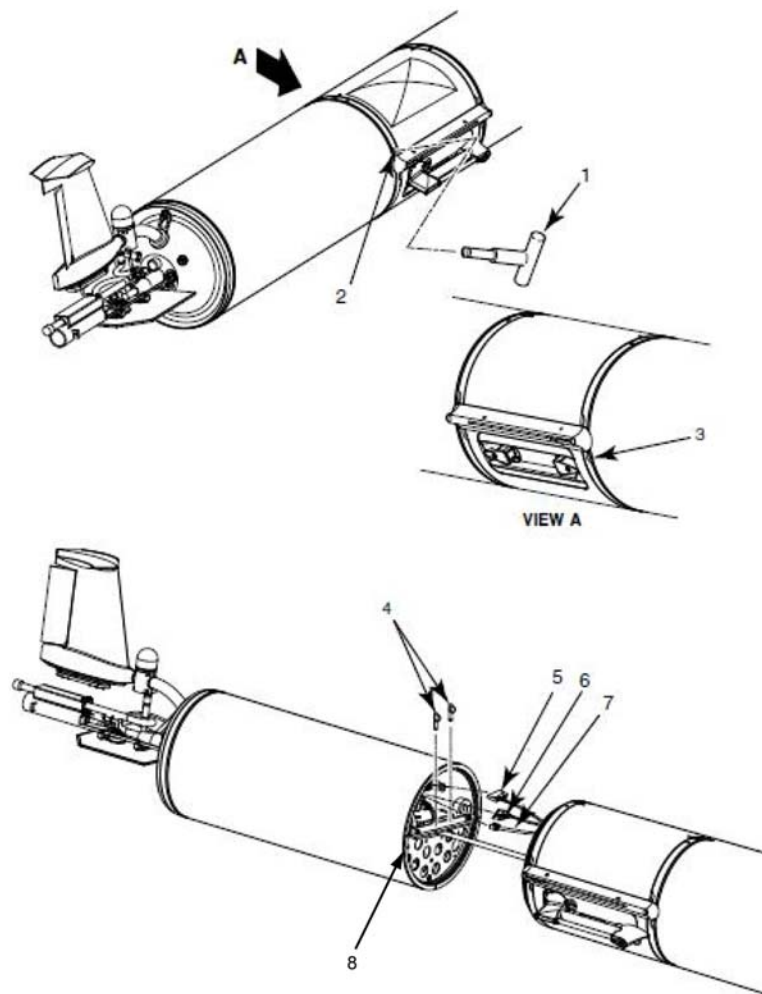
1. Loosen the wing retaining screw on each wing rail, if present.
2. Release the snap-in retaining lever located at the rear of each wing rail.
3. Pivot the wing forward and pull it out of the wing rail slot.

## Installing the Wings

1. Position the slot in the forward end of the wing in the wing rail slot where it will slide around the retaining post.
2. Pivot the wing aft until it snaps into the retaining lever on the aft end of the wing rail.
3. Tighten the wing retaining screw, if present.

# Aft Assembly

Tools:	Phillips screwdriver Hull separation tool
Materials and parts:	Aft assembly
Personnel required:	1 electronics technician
Equipment condition:	Glider is disassembled according to "Disassembling the Glider" on page 2-1.



**Figure 2-23 Aft assembly**

## Removing the Aft Assembly

1. Separate the aft hull section from the payload bay (Figure 2-23, Items 2-3) using the hull separation tool (Figure 2-23, Item 1).
2. Remove all connections (Figure 2-23, Items 5-7) from the payload bay to the aft assembly.



---

**WARNING** Lithium batteries pose a significant hazard when stored or handled improperly. The two main hazards associated with lithium sulfuryl chloride batteries and their components are fire and explosion, which could occur if the batteries are crushed, punctured, excessively heated, charged, overdischarged, short circuited, or submerged in water in a non-waterproof enclosure.

Lithium sulfuryl chloride cells are safe to handle when all of their components are adequately wrapped and sealed within a stainless steel casing. When that casing is compromised, an immediate danger is present due to exposure of the contents (and byproducts of these contents) with their new environment. Lithium metal reacts with water to produce lithium hydroxide, a corrosive liquid and hydrogen gas, which is flammable. Sulfuryl chloride (the liquid cathode) is a corrosive liquid that reacts with water to produce hydrogen chloride gas (which is toxic and corrosive) and sulfuric acid, a corrosive liquid.

Remove your jewelry before handling lithium batteries. Wear the appropriate PPE—eye protection and chemical resistant gloves—and while handling lithium batteries.

---

3. If the glider uses lithium batteries, free the aft battery pack from the payload bay by pulling the two pins (Figure 2-23, Item 4) from the battery bracket (Figure 2-23, Item 8).
4. Separate the aft hull section from the aft end cap assembly.



---

**CAUTION** The forward and aft batteries are heavy and must be supported by the hulls in their respective bays at all times. If disassembly requires removing hulls or the assembly to which the battery is affixed, the batteries should be removed from the vehicle first, or conversely disconnected and left inside in the hulls while the assembly is removed and worked on.

---

## Installing the Aft Assembly



---

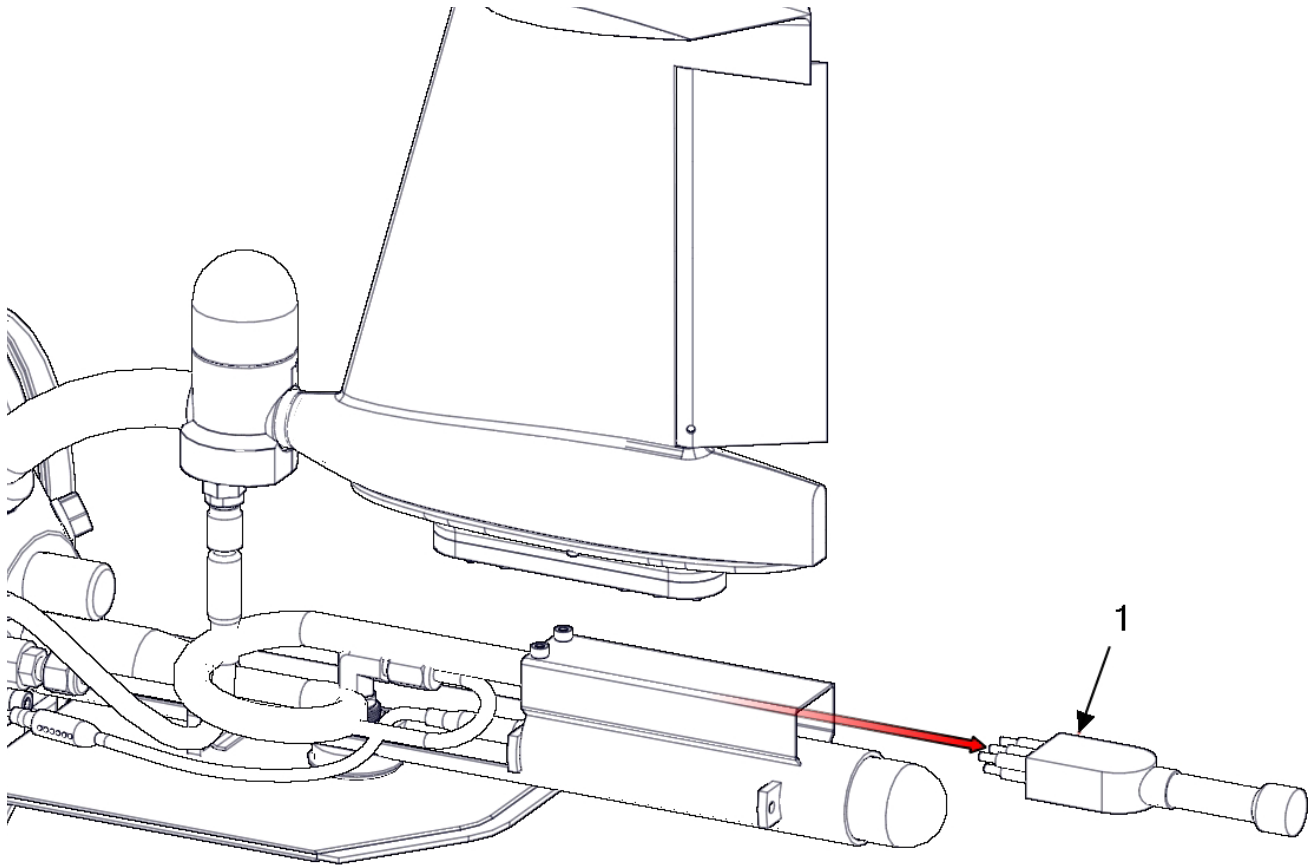
**NOTE** Refer to O-ring care.

---

1. Align the aft hull section with the aft end cap assembly.
2. If the glider uses lithium batteries, secure the aft battery pack to the battery bracket (Figure 2-23, Item 8) on the payload bay with the two pull pins (Figure 2-23, Item 4).
3. Make all connections (Figure 2-23, Items 5-7) from the payload bay to the aft assembly.
4. Align the aft hull section with the payload bay.
5. For final installation, see "Assembling the Glider" on page 2-5.

# Stop Plug (Red) and Go Plug (Green)

Tools:	None
Materials and parts:	Stop plug (red) Go plug (green)
Personnel required:	1 electronics technician



**Figure 2-24 Stop plug (red) and Go plug (green).**



## Removing the Stop Plug (Red) and Go Plug (Green)



---

**WARNING** The glider operator needs to command the glider to exit and be instructed by the glider that it is OK to remove the power before the plug can be removed. If not handled properly, the file system may become corrupt, rendering the glider inoperable. Before exiting, the operator should instruct the glider to deflate the air bladder

---

Extend the power cable and plug from the ejection weight tube and remove the Stop plug (red) or Go plug (green) (Figure 2-24, Item 1) from the glider aft end cap assembly by pulling firmly.

## Installing the Stop Plug (Red) and Go Plug (Green)



---

**NOTE** Once powered, the Slocum Glider will assume it is deployed and will run the mission `initial.mi` unless communication is established and an operator intervenes.

Before powering the glider, an operator should confirm the preferred communications method is functioning properly and have confidence that this communication method of choice is properly configured. If using Dockserver, see the *GMC Users Guide* at:

<https://datahost.webbresearch.com/files.php?cwd=/glider/production/doco/gmc>

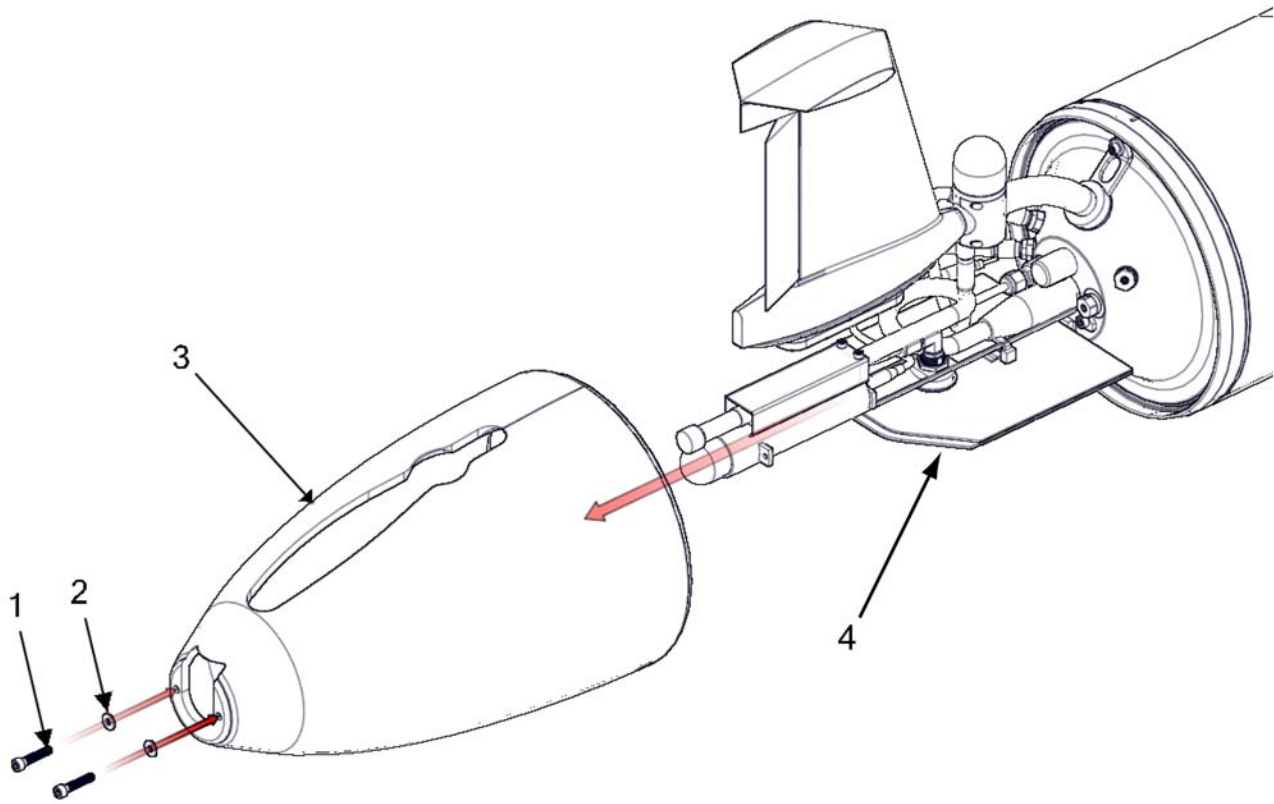
or see the *Slocum Glider Operators Manual* for instructions for configuring FreeWave and a terminal.

---

1. Before installing the Stop plug (red) or Go plug (green) (Figure 2-24, Item 1), ensure that the pins are not bent.
2. Install the Stop plug (red) or Go plug (green) (Figure 2-24, Item 1), by pushing firmly until it is seated properly.
3. Feed the power cable and plug into the ejection weight tube.

# Aft Cowling

- |                      |                          |
|----------------------|--------------------------|
| Tools:               | 5/32" hex driver         |
| Materials and parts: | Aft cowling              |
| Personnel required:  | 1 electronics technician |



**Figure 2-25 Aft cowling.**

## Removing the Aft Cowling

1. The air bladder (Figure 2-25, Item 4) must be deflated in order to remove the aft cowling (Figure 2-25, Item 3). To deflate the air bladder, type `put c_air_pump 0` from `lab_mode` or GliderDOS.
2. The glider should be powered down before removing the aft cowling (Figure 2-25, Item 3).
3. Turn off the power to glider by removing the Go plug (green) or external power cable and replacing with the Stop plug (red).
4. Remove the two 10-32 socket head cap screws (Figure 2-25, Item 1) and washers (Figure 2-25, Item 2) that hold the aft cowling (Figure 2-25, Item 3) in place using the 5/32" x 12" red T-handle hex wrench.
5. Pull the aft cowling (Figure 2-25, Item 3) back, gently separating it at the top to allow it to slide over the antenna tail fin.

## Installing the Aft Cowling

1. Slide the aft cowling (Figure 2-25, Item 3) forward, gently separating it at the top to allow it to slide over the antenna tail fin.
2. Insert the two 10-32 SHCS (Figure 2-25, Item 1) and washers (Figure 2-25, Item 2) that hold the aft cowling (Figure 2-25, Item 3) in place.

# De-PINning an Iridium SIM Card

When Iridium SIM cards are delivered from the manufacturer, they are configured so that they will work only when the user inputs a personal identification number (PIN, which is set by the manufacturer to 1111). However, the glider is not equipped to work with PINs and must be reconfigured so that Iridium communications do not require a PIN. This procedure provides step-by-step instructions to properly reconfigure (i.e., de-PIN) an Iridium SIM card that is installed in the glider. Alternatively, the SIM card may be de-PINned by following the instructions on an Iridium phone handset.

## Setup

- The Iridium SIM card must be installed in a glider that is assembled as described in "Assembling the Glider" on page 2-5 and powered on.
- Access talk iridium by typing talk iridium from PicoDOS. It is recommended that the de-PINning procedure be performed while in the glider terminal's serial port perspective.

## SIM Check

1. From talk iridium, type `at+clck=?`
2. The Low Band Transmitter (LBT) should respond with either:
  - `+clck: ("cs")` or
  - `+clck: ("cs", "sc")`



**NOTE** Several other arguments may appear in addition to "cs" and "sc", but they are not relevant to this procedure.

If the `sc` argument is missing, then the SIM card is either not properly seated in the LBT, or it requires the PIN to be deactivated. Verify that the SIM card is properly seated in the LBT, and repeat the check, if required.

## PIN Deactivation Procedure

1. Enter the PIN by typing the command `at+cpin="1111"`.
2. The LBT must respond with `ok`. (Note that the PIN must be surrounded by double quotes.)

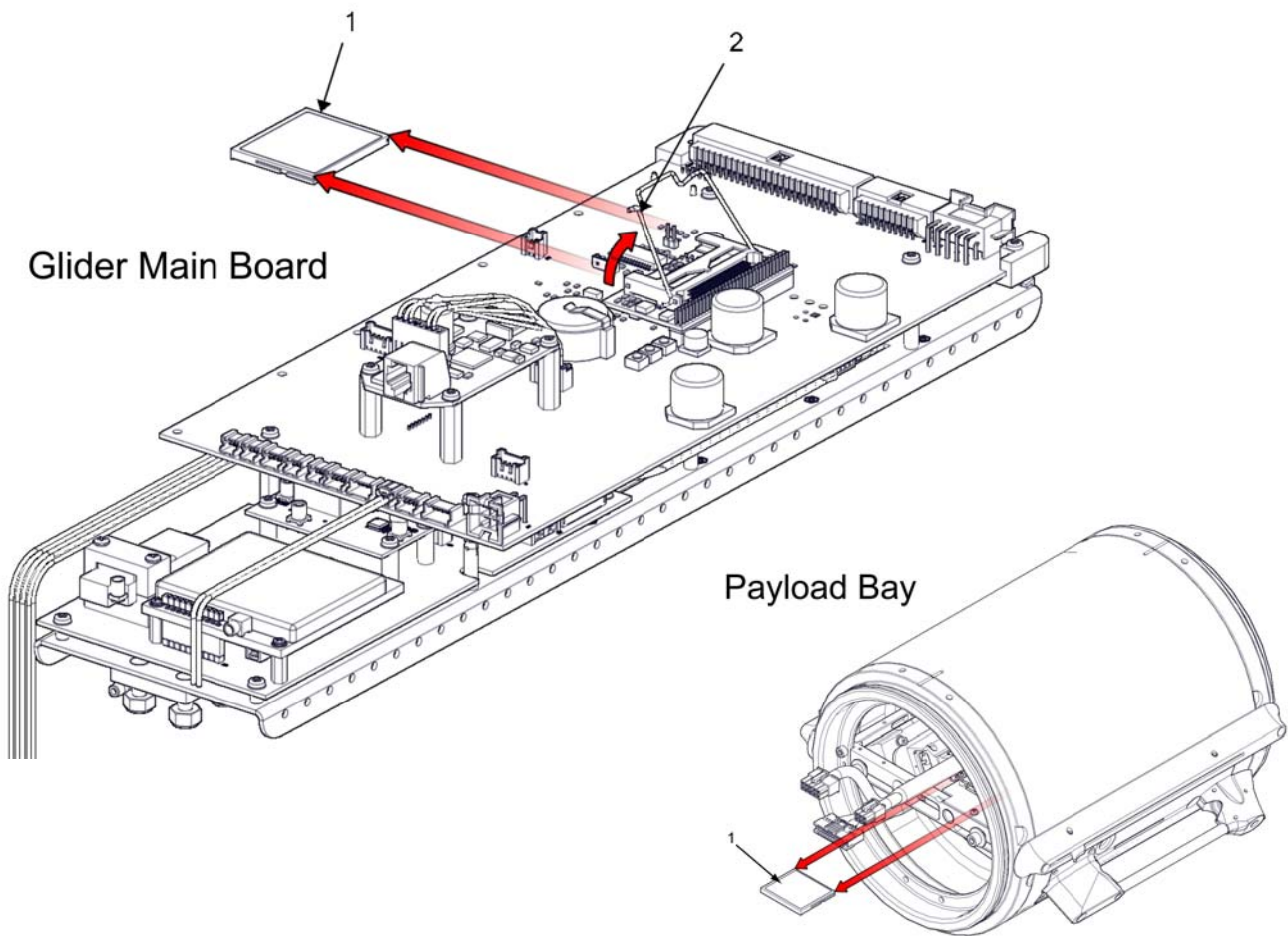
If the LBT responds with error, then either the code was typed incorrectly or the PIN has been changed from the factory default. Repeat steps 1-2 as necessary to attain an `ok` response to this command.

3. On the terminal, type the command `at+clck=?` and verify that the LBT responds with `+clck: ("cs", "sc")`.

4. Type the command `at+clck="sc",0,"1111"`. The LBT must respond with `ok`.
5. Power cycle the LBT.
6. On the terminal, type the command `at+clck=?`, and verify that the LBT responds with `+clck:("cs","sc")`. The SIM card is now configured properly.

# Compact Flash Memory Card

Tools:	Phillips screwdriver
Materials and parts:	Compact flash memory card
Personnel required:	1 electronics technician
Equipment condition:	Glider is disassembled according to "Disassembling the Glider" on page 2-1 and "Removing the Payload Bay Guard Plate" on page 2-46.



**Figure 2-26 Compact flash memory card.**

## Removing the Compact Flash Memory Card

### ***Payload Bay***

1. Disengage the compact flash memory card retaining clip (not shown).
2. Remove the compact flash memory card (Figure 2-26, Item 1).

### ***Glider Main Board***

1. Disengage the compact flash memory card retaining clip (Figure 2-26, Item 2).
2. Remove the compact flash memory card (Figure 2-26, Item 1).

## Installing the Compact Flash Memory Card

### ***Payload Bay***

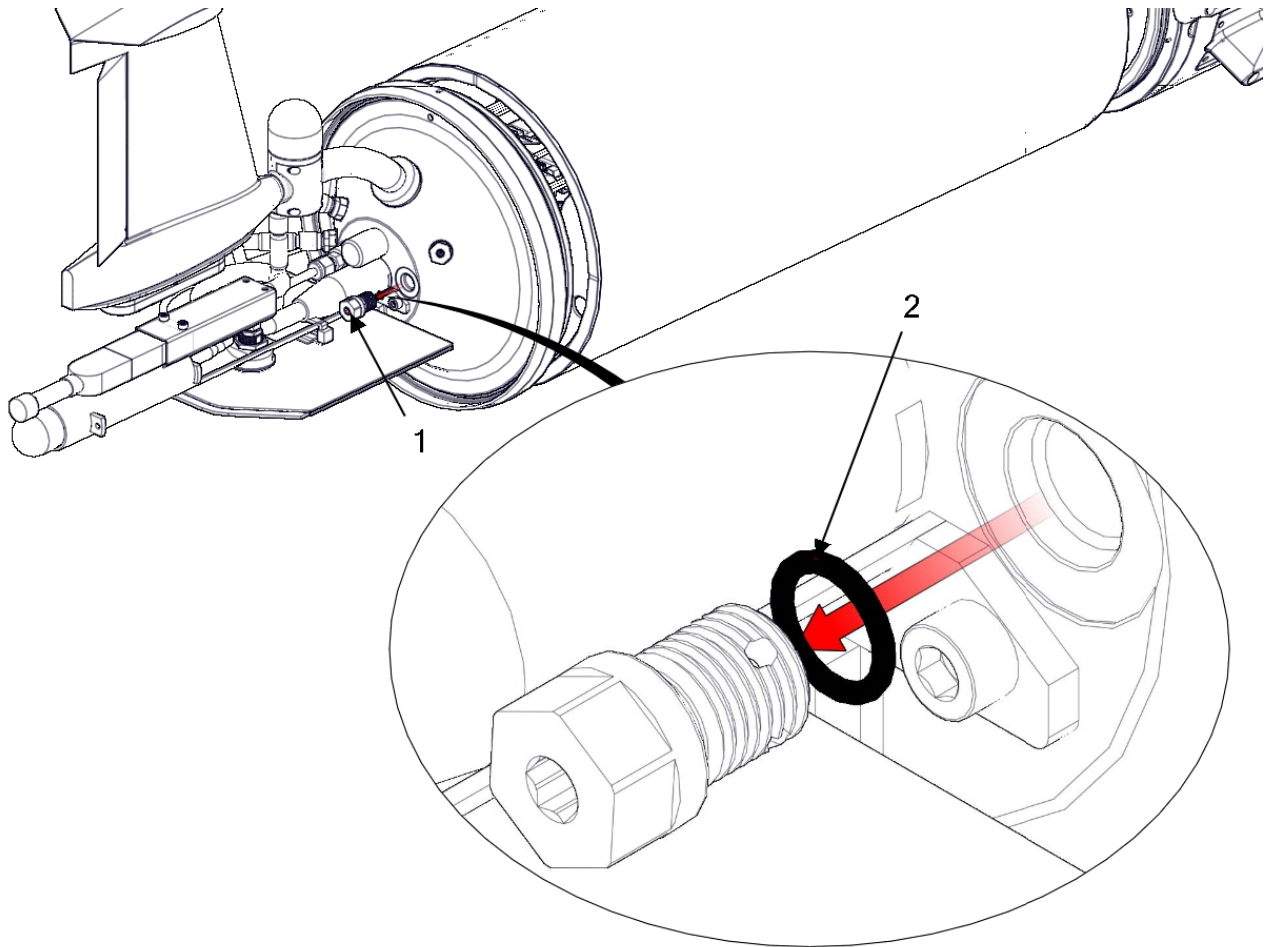
1. Install the compact flash memory card (Figure 2-26, Item 1). Ensure that the memory card's metal contacts are facing down, and slide the card into the slot until it is firmly seated.
2. Engage the compact flash memory card retaining clip (not shown).

### ***Glider Main Board***

1. Install the compact flash memory card (Figure 2-26, Item 1). Ensure that the memory card's metal contacts are facing down, and slide the card into slot until it is firmly seated.
2. Engage the compact flash memory card retaining clip (Figure 2-26, Item 2).

# MS Plug

- |                      |   |
|----------------------|---|
| Tools:               | 15 inch-pound torque T-handle<br>24" extension<br>3/16" hex bit |
| Materials and parts: | MS plug, 6/16"  |
| Personnel required:  | 1 electronics technician  |
| Equipment condition: |   |



**Figure 2-27 MS plug.**



## Removing the MS Plug



---

**WARNING** Before removing the MS plug, the internal pressure can be read from a terminal. If air is heard rushing out, this may be a sign of released hydrogen gas.

---



---

**NOTE** The MS plug should be inspected for wear and replaced if worn.

---

1. Using the 15 inch-pound torque T-handle, 24" extension and 3/16" hex bit, remove the MS plug (Figure 2-27, Item 1).



---

**CAUTION** PEEK parts are delicate. Proper tools must be used for PEEK parts and the proper torque applied, otherwise these parts may be damaged.

---

2. Remove the 3-904 O-ring (Figure 2-27, Item 2).

## Installing the MS Plug



---

**NOTE** Petroleum Naphthenic Oil and Barium Soap, such as Parker Fibrous 884-4 O-Lube, are recommended.

---



---

**WARNING** Parker O-Lube: Avoid contact with skin and eyes. If ingested immediately drink two glasses of water, induce vomiting, and seek medical attention. Keep away from open flames, hot surfaces, and sources of ignition. Fire extinguishers should be readily available when solvent is used.

---

1. Inspect the 3-904 O-ring (Figure 2-27, Item 2) for cleanliness, nicks, slices, scratches, and dents.

2. Lubricate the 3-904 O-ring (Figure 2-27, Item 2).



---

**NOTE** Before installing the O-ring, electrician's tape should be used to protect the O-ring from being cut by the threads of the MS plug.

---

3. Install the 3-904 O-ring (Figure 2-27, Item 2). Ensure that it is properly seated.
4. Using the 15 inch-pound torque T-handle, 24" extension and 3/16" hex, install the MS plug (Figure 2-27, Item 1) on the starboard side of the aft end cap. Tighten the plug to 15 inch-pounds of torque.



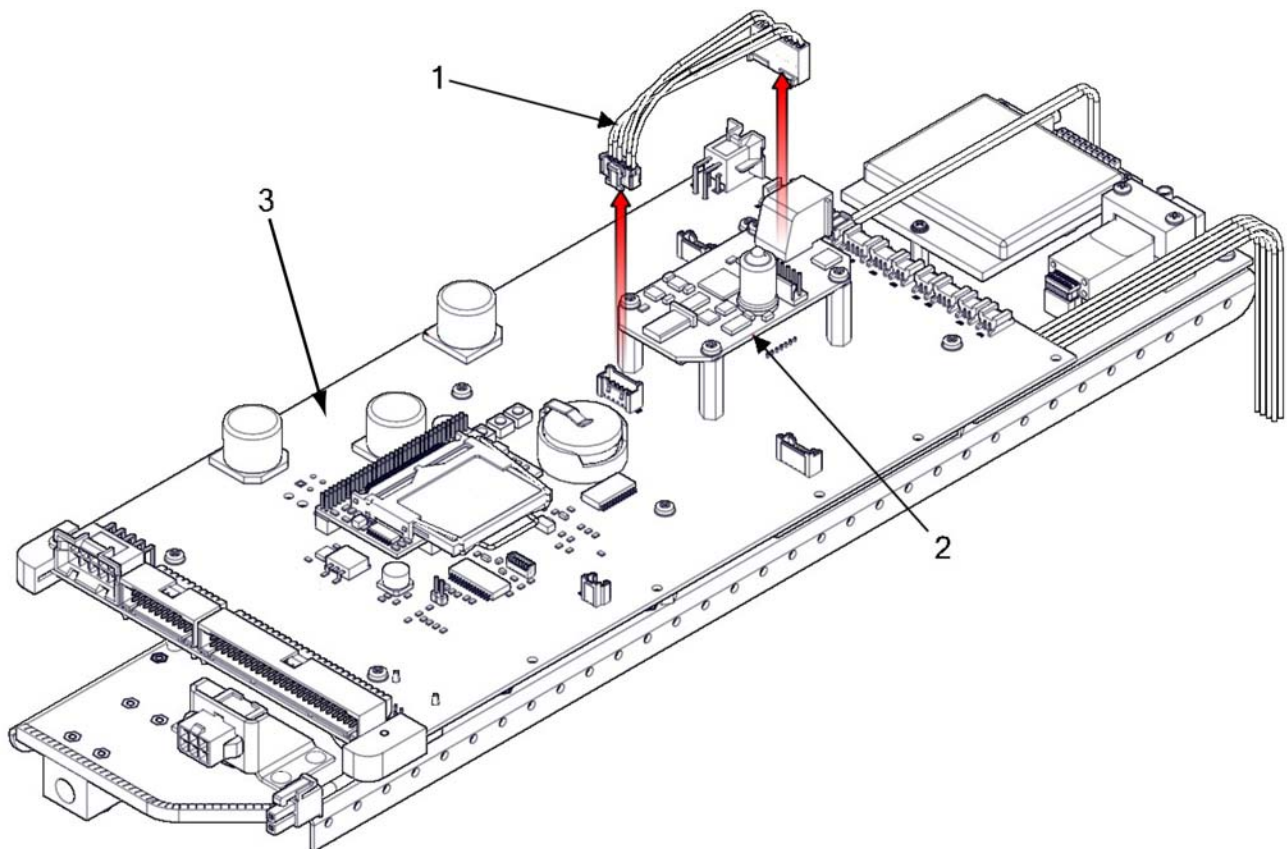
---

**CAUTION** PEEK parts are delicate. Proper tools must be used for PEEK parts and the proper torque applied, otherwise these parts may be damaged.

---

# Attitude Sensor Wiring

Tools:	None
Materials and parts:	Attitude sensor wiring
Personnel required:	1 electronics technician
Equipment condition:	Glider is disassembled according to "Disassembling the Glider" on page 2-1.



**Figure 2-28 Attitude sensor wiring.**

## Removing the Attitude Sensor Wiring

1. Disconnect the attitude sensor wiring harness (Figure 2-28, Item 1) from the glider main board (Figure 1, Item 3).
2. Disconnect the attitude sensor wiring harness (Figure 2-28, Item 1) from the true north attitude sensor (Figure 2-28, Item 2).
3. Remove the attitude sensor wiring harness (Figure 2-28, Item 1).

## Installing the Attitude Sensor Wiring



---

**CAUTION** Take care when mating connectors, as the pins are delicate.

---

1. Connect the attitude sensor wiring harness (Figure 2-28, Item 1) to the true north attitude sensor (Figure 2-28, Item 2).
2. Connect the attitude sensor wiring harness (Figure 2-28, Item 1) to the glider main board (Figure 2-28, Item 3).

## Calibrating the True North Compass

Visit the following protected resource and follow the instructions included in the readme.txt.

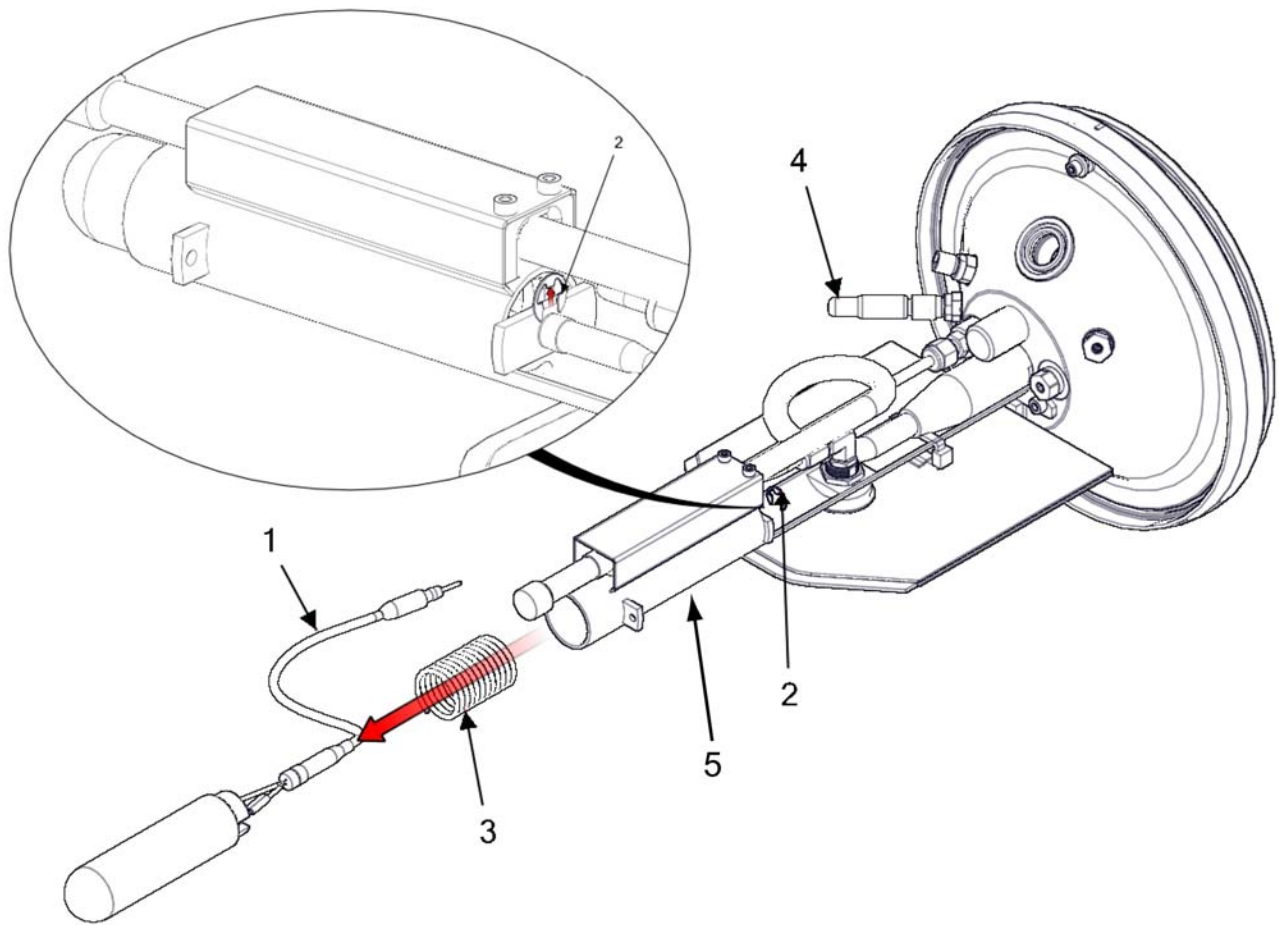
For Windows computers:

<https://datahost.webbresearch.com/files.php?cwd=/glider/windows-compass-calibrator>

The calibration tool and instructions can also be found in the Dockserver release.

# Weight Release Assembly

Tools:	None
Materials and parts:	Weight release assembly
Personnel required:	1 electronics technician
Equipment condition:	Glider is disassembled according to "Disassembling the Glider" on page 2-1.



**Figure 2-29** *Weight release assembly.*

## Removing the Weight Release Assembly



---

**NOTE** The ejection weight is a heavy, spring-loaded object that has the potential to become a dangerous projectile. Do not stand directly behind the ejection weight while removing or installing the weight release assembly. By releasing the E-ring, the ejection weight will be released. Care should be taken to hold on to the ejection weight during this procedure to prevent it from releasing violently.

---

1. Disconnect the weight release assembly (Figure 2-29, Item 1) from the weight release assembly connector (Figure 2-29, Item 4).
2. Remove the E-ring (Figure 2-29, Item 2) that secures the weight release assembly (Figure 2-29, Item 1) within the aft channel. It may be necessary to relieve pressure on the E-ring by depressing the ejection weight before the E-ring can be removed.
3. Pull the weight release assembly (Figure 2-29, Item 1) out of the aft channel. (No tools are required.)
4. Make sure the ejection weight spring (Figure 2-29, Item 3) remains in the aft channel.

## Installing the Weight Release Assembly

1. Insert the ejection weight spring (Figure 2-29, Item 3) into the aft channel (Figure 2-29, Item 5).
2. Install the weight release assembly (Figure 2-29, Item 1) through the aft channel (Figure 2-29, Item 5).
3. Install the E-ring (Figure 2-29, Item 2) that secures the weight release assembly (Figure 2-29, Item 1) within the aft channel.
4. Connect the weight release assembly (Figure 2-29, Item 1) to the weight release assembly connector (Figure 2-29, Item 4).

## Replacing the Burn Wire Assembly

If the burn wire assembly has been used and must be replaced:

1. The air bag must be deflated to easily remove the aft tail cowling. In GliderDOS, type `put c_air_pump 0`. Remove the two 10-32 SHCSs and washers that hold the aft tail cowling in place with a 5/32" hex driver.
2. Slide the cowling back and around the antenna tailfin.
3. Disconnect the single-pin Mecca connector.
4. From the single-pin male Mecca connector side, remove the burn wire bushing in the jettison weight tube.
5. Remove the E-ring from the new burn wire assembly, complete with the jettison weight attached.
6. Feed the single-pin Mecca connector through the aft end of the jettison weight tube, out the hole on the forward end.
7. With one hand, push the jettison weight into the tube, compressing the jettison weight spring. At the same time, feed the Mecca wire through the hole until the burn wire bushing appears.
8. With the face of the burn wire bushing beyond the edge of the hole, slide the burn wire slightly sideways so that it is resting on the crossbar and does not fall back through the hole.
9. Replace the E-ring on the burn wire bushing, seating it fully.
10. Allow the burn wire bushing to fit back through the hole. It will be stopped by the e-ring on the face of the crossbar.
11. Reconnect to the single-pin Mecca connector. Use Parker O-Lube lubrication (Naphthenic Oil and Barium Soap).
12. Replace the aft end cowling.

## Main Hull O-Rings

Tools:	3/32" hex wrench
Materials and parts:	Recovery spool base (200/1000M)
Personnel required:	1 electronics technician
Equipment condition:	Glider is disassembled according to "Disassembling the Glider" on page 2-1 and "Removing the Recovery Assembly" on page 2-26.

### Removing the Main Hull O-Rings

1. Separate the glider hulls and payload bay.
2. Remove the O-rings.

### Installing the Main Hull O-Rings



---

**WARNING Parker O-Lube: Avoid contact with skin and eyes. If ingested immediately drink two glasses of water, induce vomiting, and seek medical attention. Keep away from open flames, hot surfaces, and sources of ignition. Fire extinguishers should be readily available when solvent is used.**

---

1. Inspect the O-rings for cleanliness, nicks, scratches, dents, and slices.
2. Lubricate the O-rings with Parker O-Lube.
3. Install the O-rings. Ensure that the O-rings are seated properly.



# 3 Ballasting



---

**CAUTION** Many of the operator instructions below are harmless when used in the lab. Some commands below cannot be used safely when the glider is deployed and in a mission.

---



---

**CAUTION** Never power a glider without a vacuum.

---

The goal of ballasting is to adjust the mass of the glider so that it is neutrally buoyant and properly trimmed at the surface of the operation site's water when:

1. The displacement pump is set to 0 cc.
2. The pitch vernier is set to 0 inches.
3. The static roll is set to 0 degrees.
4. The air bladder is deflated.

The `ballast` command from lab mode moves these motors to the proper position.



---

**NOTE** See Appendix A of the *Slocum G3 Glider Operators Training Guide* for a list of commonly used glider commands.

---

## Checking and Setting the Vacuum

If the glider is not closed with a proper vacuum already, you need to check and set the vacuum before applying power to the glider. For the steps on how to do this, see "Checking and Setting the Vacuum on the Glider" on page 2-9.

## Turning on the Science Sensors

When ballasting for a CTD or to confirm science output, you need to display science data in real-time from the glider so that you can make your final weight adjustment calculations from the ballast tank to real-world conditions.

As an alternative to the steps below, an operator can type the following commands to turn on and off all of the sensors in the science bay.

```
Loadmission sci_on.mi
```

```
Loadmission sci_off.mi
```

1. Type `put c_science_all_on 0 (off=-1)`. This tells the science computer to sample all science sensors as fast as possible.
2. Type `put c_science_on 3 (off=1)`. This displays that data to the screen.
3. Type `put c_science_send_all 1 (off=0)` to send science data to the flight Persistor.
4. When ballasting, use the water's temperature and conductivity to calculate your salinity and density. Enter this data into the ballasting and H-moment calculator sheet in the appropriate cells. Enter the target water's temperature, density, and salinity into the appropriate cells to get your total weight change from tank to real-world conditions.

## Setting the Glider to **ballast** Mode

1. Power the glider with either an external power cable (15 VDC), or insert the go plug (green) as described in "Stop Plug (Red) and Go Plug (Green)" on page 2-52.
2. If in PicoDOS, run the application (type `app`) to start GliderDOS.
3. Once in GliderDOS, type `ctrl-c`, when appropriate, to gain control of the glider.
4. Type `callback 30`.
5. Type `Lab_mode on`.
6. Type `ballast`. This will set the ballast pump and pitch vernier to 0, and deflate the air bladder.
7. If external power is used, type `exit`, pull the plug, and replace it with a red dummy plug when the glider states it is OK to remove the power as described in "Stop Plug (Red) and Go Plug (Green)" on page 2-52.
8. If internal power is used, the glider may remain on.

## Immersing the Glider into the Test Tank

1. Place the glider in the test tank, making sure to purge the nose cone and aft cover of bubbles. This can be accomplished by gently bumping the glider's nose into the wall of the tank and tapping the aft cover until all bubbles have been eliminated. The HD pumps have a much larger volume that must be cleared of air entrapment to ensure proper ballasting. Take great care to ensure all exterior air has been purged from the vehicle
2. Insert the wings into the wing rails (see "Payload Bay Assembly" on page 2-45).
  - If your tank is not large enough to attach the wings, lay the stacked wings on top of the aft hull section, aligning the holes of the wings with the aft holes of the wing rails.
  - Hold the wings in place with a wrap of electrical tape around the hull and wings.

## Adjusting the Glider's Weight



---

**NOTE** The steps below outline the process necessary to properly ballast the glider. To this end, Teledyne Webb Research has developed the **Ballast Adjustment Spreadsheet** to assist in the ballasting process. Contact **Glider Support** for a copy and for information and assistance regarding its use.

---

1. If the glider is too light, add weight to the exterior of the hull in the areas where internal weight adjustments can be made.
  - Weight can be added where the forward and aft end caps attach to the hull, and at the forward and aft ends of the payload bay.
  - In ballasting the vehicle in a tank, it is often desirable to lay external weight on the hull to trim the overall weights and moments. These weights displace water, which should be accounted for before adjusting the vehicle's internal weight. For stainless steel the external air weight times 0.875 equals the internal weight to be added. For lead the external air weight times 0.912 equals the internal weight to be added
  - The internal weight and balance of the glider can be altered through changes to stainless steel weights, shot in ballast bottles, batteries, and payload:
  - The forward hull section has room for two ballast bottles (see "Ballast Bottles" on page 2-17). The 200-meter gliders powered by lithium batteries are also outfitted with steel weights mounted in the unused battery brackets.
  - The forward and aft ends of the payload bay can be fitted with pie-shaped stainless roll weights, and the payload itself (such as science packages and batteries) can be shifted. Additionally, weight bars with tapped holes may be installed in the payload bay to which stainless steel plates and/or ballast bottles can be attached.
2. If the glider is too heavy, attach spring scales to the glider where the forward and aft end caps attach to the hull to determine the balance and overall excess weight.

3. Because the glider's mass has been adjusted to make it neutrally buoyant in the tank, these results must be compared to the buoyancy required by the target surface water. The weight that the glider must be adjusted when transferred between bodies of water with different densities and temperatures is calculated from the following equation:

$$W = D_{glider} \left[ \alpha_{glider} P_{target\ water} (T_{target\ water} - T_{tank\ water}) + \left( \frac{P_{target\ water}}{P_{tank\ water}} - 1 \right) \right]$$

where:

$D_{glider}$  = Displacement of glider (assumed to equal the glider's air weight)

$\alpha_{glider}$  = Thermal coefficient of expansion for the glider (=  $535 \times 10^{-6}$ )

$P_{target\ water}$  = Density of target water (in g/L)

$P_{tank\ water}$  = Density of tank water (in g/L)

$T_{target\ water}$  = Temperature of target water (in degrees C)

$T_{tank\ water}$  = Temperature of tank water (in degrees C)

W = Weight to adjust the glider (g)

Glider Type	Glider Displacement, $D_{glider}$ (L)
G1 (200 m)	52.0
G1 (1000 m)	55.2
G3 (200 and 1000 m)	56.3
Additional science bay	9.0
G3	57.3

## Calculating the H-Moment

H-moment, or horizontal moment, is the measure in millimeters of the distance between the center of buoyancy and the center of gravity of the glider. This can be thought of as similar to the measure of stability or righting moment in a boat. Unlike a boat, a glider requires the distance between the center of gravity and buoyancy to be relatively close. This proximity and fine-tuning of this small distance is a major component of glider flight dynamics and energy consumption. The recommended distance is 5-6 mm between these two locations. To achieve the proper neutral pitch, the weights may need to be shifted fore or aft internally. The pitch vernier will take care of some offset, provided that the H-moment is ideally set from 5 to 6 mm.

Teledyne Webb Research provides two methods to measure the H-moment value:

- A change in the moment by adding mass to the wing and measuring the vehicle's change in roll.
- Commanding the vehicle to move the pitch battery mass and measuring the vehicle's change in pitch.

Ultimately, a glider with too large of an H-moment or distance between the center of buoyancy and gravity would be considered too "stiff," and energy will be consumed by moving the pitch battery greater distances internally, or if grossly in error, the glider may not be able to dive and climb at all and may only "pancake" through the water column. If the H-moment locations are too close together, the glider is considered too "twitchy" or unstable, and energy will be consumed, continually correcting the vehicle's pitch, or if grossly in error, the glider might flip over.

It is important to remember that you need to make the glider neutral in the ballast tank and do an H-moment calculation. If you intend to measure the glider's H-moment, it should be calculated before making a final mass adjustment.

## Calculating the H-Moment

To calculate the H-moment, with the glider powered and neutral in the tank: Type `report ++ m_pitch m_battpos`. This displays the pitch and battpos of the glider every CPU cycle in radians and inches respectively. Follow the instructions for calculating the H-moment on the ballasting and H-moment calculator spreadsheet.

## Adjusting the H-Moment

A properly ballasted glider will measure 5-6 mm H-moment. To increase the H distance, the mass should be moved from high to low. To decrease the H-moment vehicle, the mass should be moved from low to high. Typically the pie shaped masses attached to the payload bay are used to make these adjustments. H-moments of 4-7 will be acceptable in some instances. Users may want to move closer to 7 for operations that will intend to employ heavy thruster use.



# 4 Parts List and Equipment Returns

## Ancillary Glider Equipment

This equipment is shown in the table below.

**Table 4-1 Ancillary Glider Equipment**

Equipment Type	Description
Ballast tank	Minimum size: 8' (2.5 m) long x 4' (1.2 m) X 3' (1 m). This is for a manual setup of the glider. A way to get the glider in and out of the tank (i.e., an overhead winch, a low enough tank to go over the side, or some lifting device).
Vacuum pump	Thomas model #2688CE44, available from Grainger (Grainger item #5Z350) or equivalent, to pull the glider's vacuum.
Gram scale	0-2 kg; to measure the internal ballast.
Hanging gram scale	To measure the weight of the glider in the ballast tank.
Lead shot or ballast material	—
Iridium account	See Appendix F in the <i>Slocum G3 Glider Operators Manual</i> for more information.
Argos account and ID	See Appendix G in the <i>Slocum G3 Glider Operators Manual</i> for more information.
Land phone line	To receive Iridium satellite, or introduced in 2008, Rudics is available for data transfer.

# Instructions for Returning Equipment for Repair or Refurbishment

Contact Teledyne Webb Research Customer Support at [glidersupport@teledyne.com](mailto:glidersupport@teledyne.com) and ensure that the issue cannot be resolved remotely. Never Return Equipment with first requesting and receiving an RMA and return instructions.

RMA's can be requested at the following link:

<http://www.teledynemarine.com/webb-research/rma/>



**NOTE All large crates (APEX and GLIDER) must be metal banded.**

**Teledyne Webb Research ships APEX and GLIDER by air. We strongly discourage truck transport over long distances due to the likelihood of additional damages during shipping.**

## Typical Crate Dimensions

These dimensions are shown in the table below.

**Table 4-2 Typical Crate Dimensions**

Product Type	Crate Dimensions
APEX Floats	Single crate—82" x 15" x 17" @ 136 lbs Double crate—82" x 22" x 17" @ 219 lbs If returning APEX floats with lithium batteries installed, follow IATA shipping, labeling, and documentation requirements.
Slocum Glider (large gray shipping crate)	95" x 29" x 34" @ 429 lbs If returning the glider with lithium batteries installed, follow IATA shipping, labeling, and documentation requirements.
Slocum glider battery crate (alkaline)	34" x 12" x 12" @ 70 lbs
Slocum glider lithium battery box	1 UN certified cardboard box 34" x 27" x 15" @ 80 lbs If returning lithium batteries, follow IATA shipping, labeling, and documentation requirements.



## Additional Instructions

### ***Floats***

If the float has been in the ocean and might contain water, please remove the seal plug for shipping. If the float is active, turn it off, and using the interface cable, issue the command H (hibernate) as described in final test procedure. Use the original shipping crates, and ensure all foam supports are installed.

### ***Gliders***

If the glider is suspected to, or has leaked and may contain seawater, please remove the seal plug for shipping. If no leak is suspected, please return the gliders with the appropriate vacuum set. For deep gliders, fully retract the oil. Use the original shipping crate, and be sure both black ratchet straps are securely fastened around the glider and are firmly holding the glider and cart into the brackets.

If you are in any doubt or need any additional assistance, contact customer support at [glidersupport@teledyne.com](mailto:glidersupport@teledyne.com).



# A Abbreviations and Acronyms

ABBREVIATION OR ACRONYM	DESCRIPTION
AC or ac	Alternating Current
ASSY	Assembly
BAM	Beam Attenuation Meter
CTD	Conductivity/Temperature/Depth
COTS	Commercial Off-The-Shelf
DC or dc	Direct Current
DG	Dangerous Goods
GLMPC	Glider Mission Planning and Control
GMC	Glider Mission Control
GPS	Global Positioning System
IR	Infrared
ISO	International Organization for Standardization
ISU	Iridium Subscriber Unit
LNA	Low Noise Amplifier
MS Plug	Military Standard Plug
MSDS	Material Safety Data Sheet
OC	Operations Center
OEM	Original Equipment Manufacturer
QCP	Quality Control Process
PPE	Personal Protective Equipment
RHEL	Red Hat Enterprise Linux
RHN	Red Hat Network
RUDICS	Router-based Unrestricted Digital Internetworking Connectivity System
SE	Systems Engineering
SHCS	Socket Head Cap Screw
SN	Serial Number
SOP	Standard Operating Procedure
SSL	Secure Sockets Layer

ABBREVIATION OR ACRONYM	DESCRIPTION
STE	Secure Telephone Equipment
TWR	Teledyne Webb Research
U.S.	United States
USB	Universal Serial Bus
UUV	Unmanned Undersea Vehicle
VAC	Volts Alternating Current